

ACCUVALVE® MODEL AVC2000 SUBMITTAL

MODEL CODE

⚠ WARNING: NOT FOR USE WITH PERCHLORIC ACID

AVC2 - -

VALVE HOUSING MATERIAL

- 2 = 304SS, 20 GAUGE
- 3 = 316SS, 20 GAUGE
- 4 = ALUMINUM, 16 GAUGE

OPTIONS

- BLANK = NO OPTIONS
- F = FLANGES (REF NOTES 2 & 3)
- I = INSULATION (REF NOTE 4)
- S = TIGHT SHUT-OFF (REF NOTE 1)

SIZE

- 06 = 06" DIAMETER
- 08 = 08" DIAMETER
- 10 = 10" DIAMETER
- 12 = 12" DIAMETER
- 14 = 14" DIAMETER
- 18 = 12"x18" RECTANGULAR
- 24 = 12"x24" RECTANGULAR

ACTUATOR

- 17 = FAIL LAST POSITION (FLP), 10 SEC

MODEL CODE NOTES:

- 1) Blade seals are standard on all 6" valves, therefore -S option is not available for valve size -06.
- 2) Reference the Flange Detail - Vanstone submittal drawing for round flanges
- 3) Reference the Flange Detail - Rectangular submittal drawing for rectangular flanges
- 4) Reference the Insulation detail submittal drawing

MATERIALS

Materials Exposed to the Airstream			
Model Material Designator	(2) 304SS	(3) 316SS	(4) Aluminum
Housing	304 Stainless Steel	316 Stainless Steel	Al. Alloy 5052-H32
Compression Section	304 Stainless Steel	316 Stainless Steel	Al. Alloy 5052-H32
Static Regain Section	304 Stainless Steel	316 Stainless Steel	Al. Alloy 5052-H32
End Plate	304 Stainless Steel	316 Stainless Steel	Galvanized Steel
Blades	304 Stainless Steel	316 Stainless Steel	Galvanized Steel
Shafts	316 Stainless Steel	316 Stainless Steel	316 Stainless Steel
Shaft Bearings	Teflon	Teflon	Teflon
Vortex Sensors	Polycarbonate Plastic, UL94-V0	Polycarbonate Plastic, UL94-V0	Polycarbonate Plastic, UL94-V0
Sensor Tubing	Polyurethane, Ether-based	Polyurethane, Ether-based	Polyurethane, Ether-based
Compression Seals	Viton Rubber	Viton Rubber	EPDM Rubber
Machine Screws	304 Stainless Steel	316 Stainless Steel	304 Stainless Steel
Rivets	304SS	316SS	304SS
Blade Seals (optional)	Viton Rubber	Viton Rubber	EPDM Rubber

OPERATING RANGE

Valve Model	Min. Flow Measured			Full Scale Range		
	CFM	L/S	CMH	CFM	L/S	CMH
AVC2X06-XX	30	14	51	315	149	535
AVC2X08-XX	80	38	136	800	378	1359
AVC2X10-XX	120	57	204	1300	613	2209
AVC2X12-XX	180	85	306	1790	845	3041
AVC2X14-XX	250	118	425	2750	1298	4672
AVC2X18-XX	260	123	442	3200	1510	5437
AVC2X24-XX	350	165	595	4000	1888	6796

SIZE AND WEIGHT

Valve Model	Valve Dimensions (Reference Sheet 2)						Weight					
	"D" or "W"		"L" (Note 1)		"H"		Stainless Steel		Aluminum		Flange Add	
	in.	mm	in.	mm	in.	mm	Lbs.	kg	Lbs.	kg	Lbs.	kg
AVC2X06-XX	5.88	149	22	559	10	254	13	5.9	9	4.1	2.0	0.9
AVC2X08-XX	7.88	200	24	610	12	305	16	7.3	12	5.4	2.6	1.2
AVC2X10-XX	9.88	250	24	610	14	356	20	9.1	14	6.4	3.2	1.5
AVC2X12-XX	11.88	300	27	686	16	406	26	11.8	16	7.3	4.5	2.0
AVC2X14-XX	13.88	350	30	762	18	457	30	13.6	20	9.1	5.2	2.4
AVC2X18-XX	17.88	454	30	762	17	432	43	19.5	26	11.8	5.0	2.3
AVC2X24-XX	23.88	607	30	762	17	432	49	22.2	29	13.2	5.5	2.5

SIZE AND WEIGHT NOTES:

- 1) Round valves with optional flanges "L" is 1/2" (13mm) less than standard valves



Accutrol Representative:

SUBMITTAL DRAWING

AccuValve® Model AVC2000

THIS DOCUMENT IS SUBJECT TO CHANGE WITHOUT NOTICE.
THIS DOCUMENT OR THE CONTENTS THEREOF SHALL NOT BE MODIFIED WITHOUT PRIOR WRITTEN PERMISSION BY ACCUTROL LLC.

DWG. NO:	AVC2000 SUBMITTAL DWG		
REVISION:	C	ECN:	2748
REV. DATE:	12-1-21	SHEET:	1 OF: 5

ROUND VALVE

AVC2X06-XX
 AVC2X08-XX
 AVC2X10-XX
 AVC2X12-XX
 AVC2X14-XX

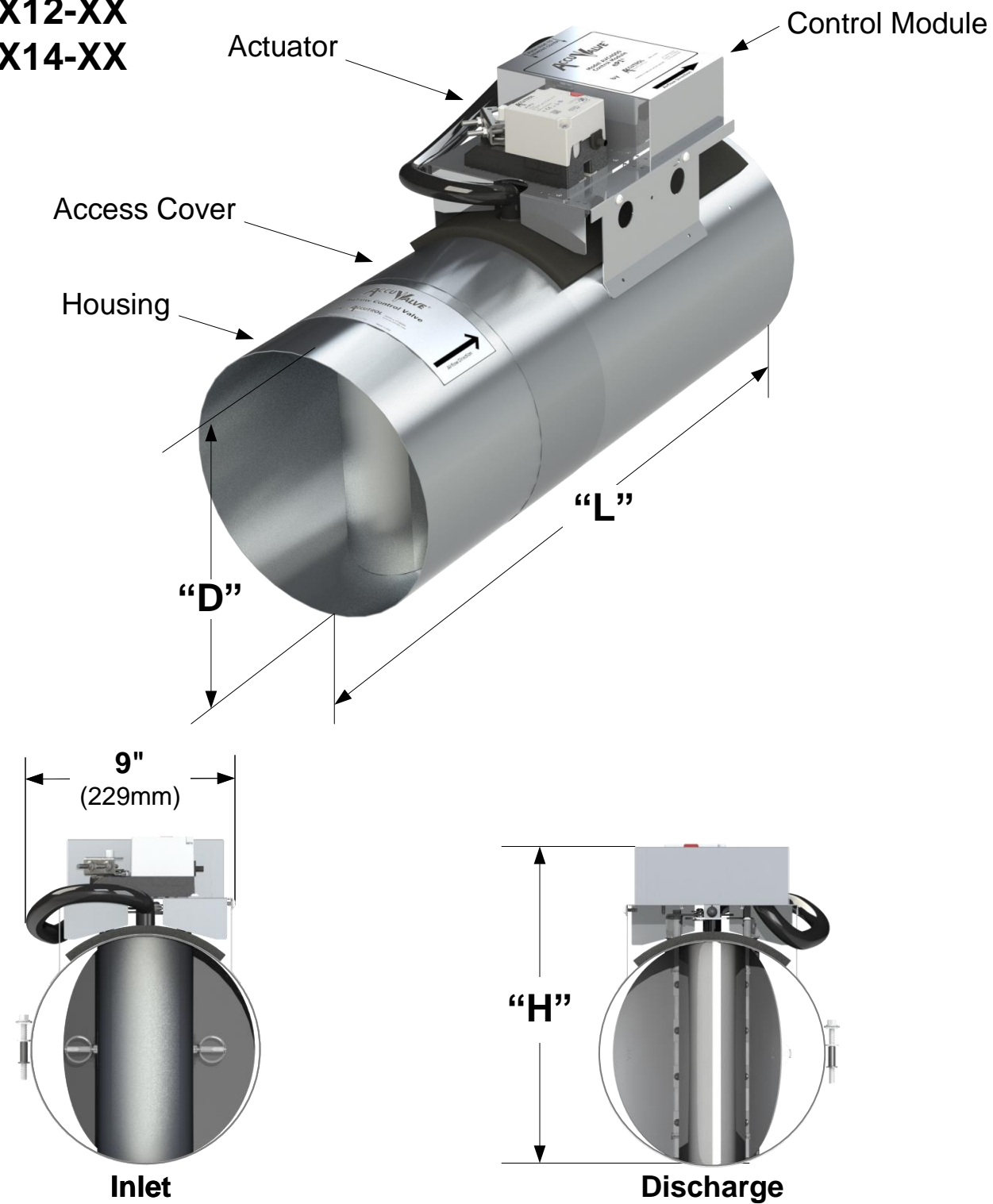

RECTANGULAR VALVE

AVC2X18-XX
 AVC2X24-XX

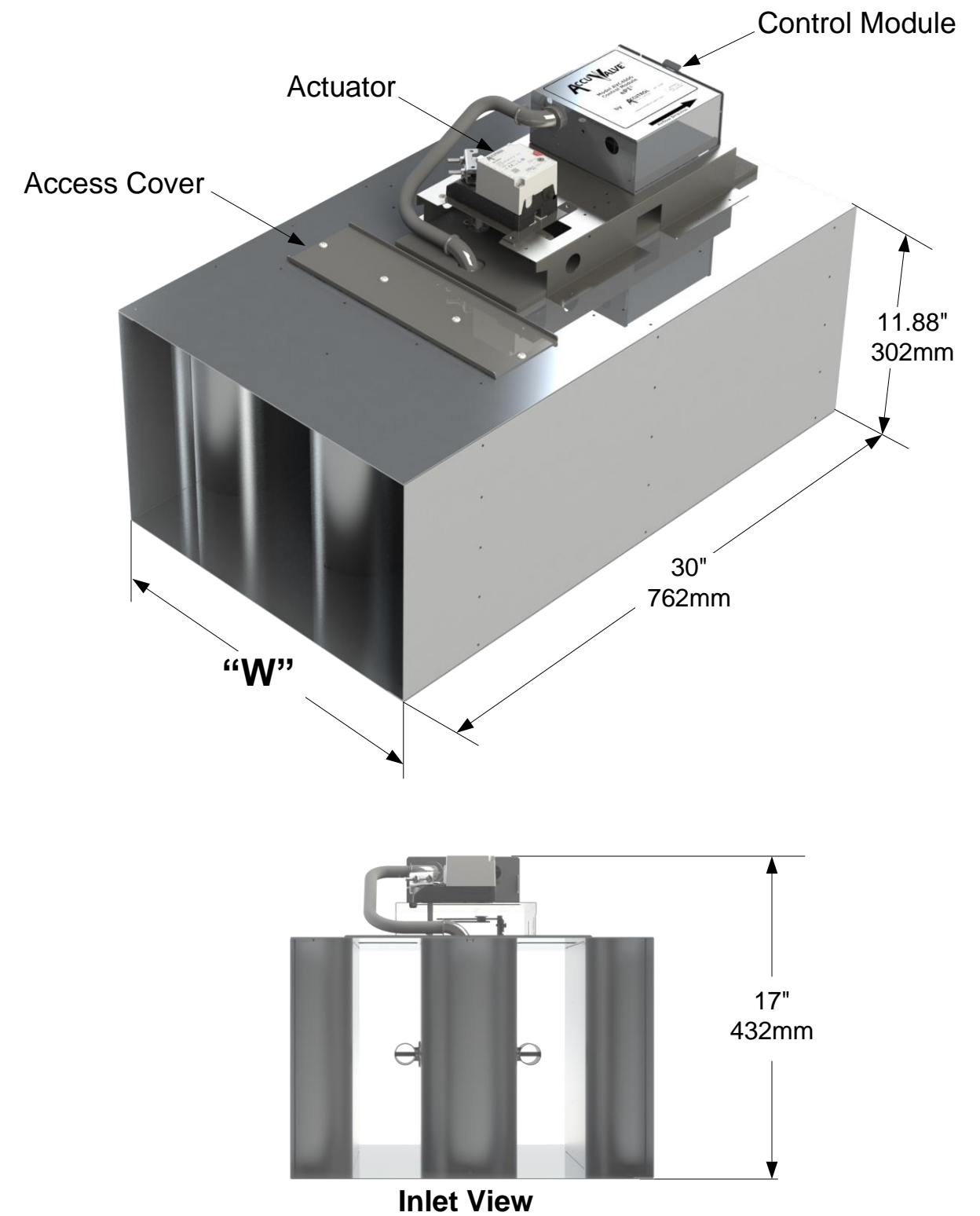

DWG. NO:	AVC2000 SUBMITTAL DWG		
REVISION:	C	ECN:	2748
REV. DATE:	12-1-21	SHEET:	2 OF: 5

ROUND VALVE: INSTALLATION INSTRUCTIONS

⚠ WARNING: Wear eye protection, protective gloves and clothing suitable for working with sheet metal which may have sharp edges.

1. Read all instructions prior to beginning installation.

NOTE: For detailed installation instructions, refer to the AccuValve® Installation & Operation Manual.

2. Verify the tag number located on the valve label matches the HVAC schedule, when applicable.

3. Locate the duct section which the valve is servicing and select a suitable mounting location for the valve.

NOTES: The AccuValve® does not require straight inlet duct runs to operate properly, however it's always best to locate the valve away from transitions and bends to minimize impact on system static pressure. Be sure to select a location that will provide a minimum clearance of 14 inches (356 mm) unobstructed access to the control module, actuator and valve access cover. The AccuValve® is not position sensitive. It can be installed in any plane or rotational axis without having impact on the performance.

4. Provide an opening in the selected duct section sized appropriately for the valve being installed.

NOTE: A slip-fit valve will require an opening approximately 2" (50.8 mm) smaller than the valve length, whereas a flanged valve will require an opening the same length as the valve. Reference Sheet 1 and 2 for valve dimensions.

5. Install duct hangers within 12 inches (305 mm) from each end of the valve. Reference Sheet 1 for valve weights.

⚠ WARNING: Use duct hangers and hardware designed to support the total load of valve and associated duct sections. Failure to do so may result in serious personal injury or death.

6. Install the valve into the duct in accordance with the airflow direction label located on the valve. Position the valve for easy access to the control module side then secure to duct per the appropriate figure below.

NOTE: Screws, nuts, fasteners, duct sealant, hangers, and gaskets are not provided by Accutrol LLC.

Standard Slip-fit Valve Secured Using Tek Screws

Seal joints using duct sealant and secure valve to duct at both ends using Tek screws.

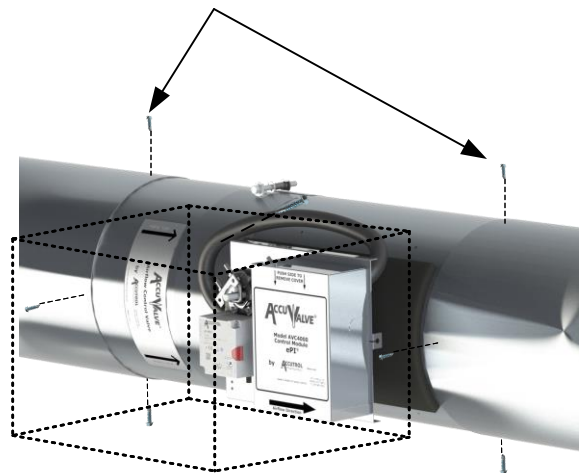

14" (356mm)
Keep-Out Zone

Figure 1

Standard Slip-fit Valve Secured Using Draw Bands

(Draw Bands are Sold Separately)

After sealing joints with appropriate type of tape, secure both ends using draw band clamps.

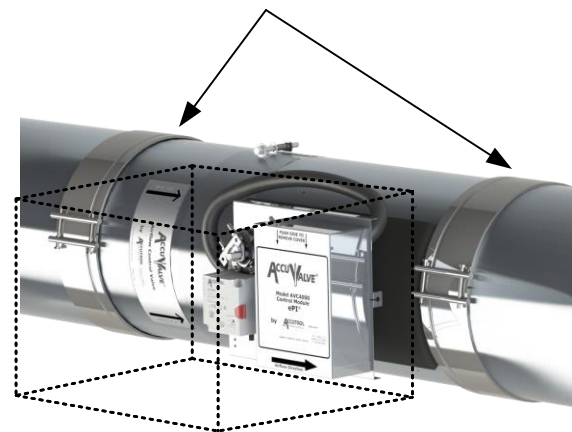

14" (356mm)
Keep-Out Zone

Figure 2

Flanged Valve "Option F" Secured Using Companion Flanges

(Companion Flanges are Sold Separately)

Install companion flanges to duct ends and secure to duct. Apply duct sealant and/or gasket to flange face. Install valve and rotate Vanstone flanges to align with bolt holes on the duct flanges. Secure flanges using appropriate hardware.

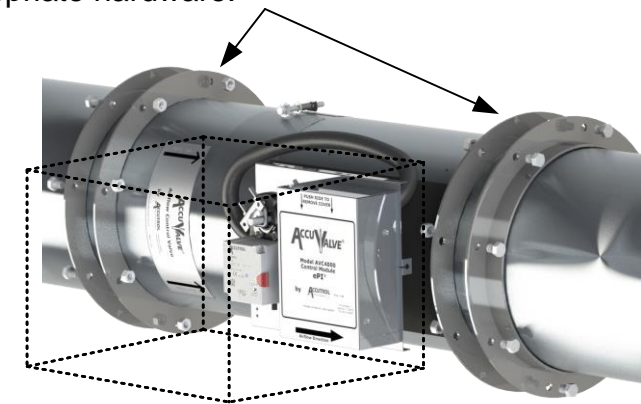

14" (356mm)
Keep-Out Zone

Figure 3

Reference Accutrol Draw Band Clamp Submittal Drawing for Details

Reference Accutrol Vanstone Flange Submittal Drawing for Details



Accutrol Representative:

SUBMITTAL DRAWING

AccuValve® Model AVC2000

THIS DOCUMENT IS SUBJECT TO CHANGE WITHOUT NOTICE.
THIS DOCUMENT OR THE CONTENTS THEREOF SHALL NOT BE MODIFIED WITHOUT PRIOR WRITTEN PERMISSION BY ACCUTROL LLC.

DWG. NO:	AVC2000 SUBMITTAL DWG		
REVISION:	C	ECN:	2748
REV. DATE:	12-1-21	SHEET:	3 OF: 5

RECTANGULAR VALVE: INSTALLATION INSTRUCTIONS

1. Read all instructions completely before installing the valve.

! WARNING: Wear eye protection, protective gloves and clothing suitable for working with sheet metal which may have sharp edges.

2. Verify the tag number located on the valve label matches the HVAC schedule when applicable.

3. Select optimum mounting location for the valve.

NOTE: The AccuValve® does not require straight inlet duct runs to operate properly, however it's always best to locate any duct device away from transitions and bends to minimize impact on system static pressure.

4. Allow a minimum clearance of 14 inches (356 mm) unobstructed access to the controller, actuator and valve access cover.

NOTE: Rectangular valves are normally installed with the "access side" facing downwards for easy access. However, the AccuValve® is not position sensitive. It can be installed in any plane or rotational axis without having impact on the performance.

5. To support the weight of the valve, install duct hangers within 12 inches (305 mm) of valve connections. Reference Sheet 1 for valve weights.

! WARNING: Use duct hangers and hardware designed to support the total load of the valve and associated duct sections. Failure to do so may result in serious personal injury or death.

6. After the duct section is properly supported to carry the weight of the valve, install valve into the duct in accordance with the airflow direction label located on the valve. Position valve so the controller, actuator and access cover are easily accessible.

7. Reference the appropriate diagram to the right for installation details.

NOTE: Screws, nuts, fasteners, duct sealant, hangers, companion flanges and gaskets are not provided by Accutrol LLC.

RECTANGULAR VALVE: INSTALLATION DIAGRAMS

Figure 1

Standard Slip-fit Valve Using Tek Screws

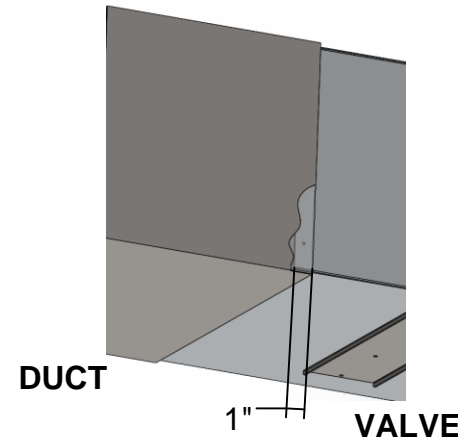

For slip-fit applications valve must be inserted at least 1" into ductwork to cover open holes on valve housing.

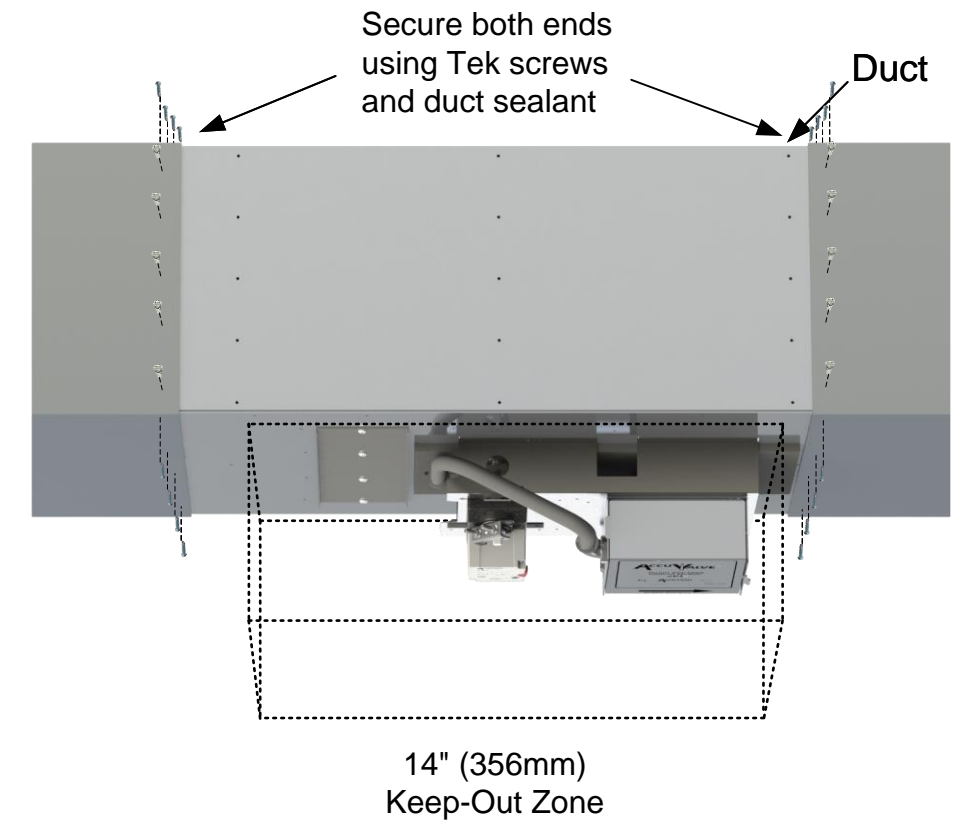
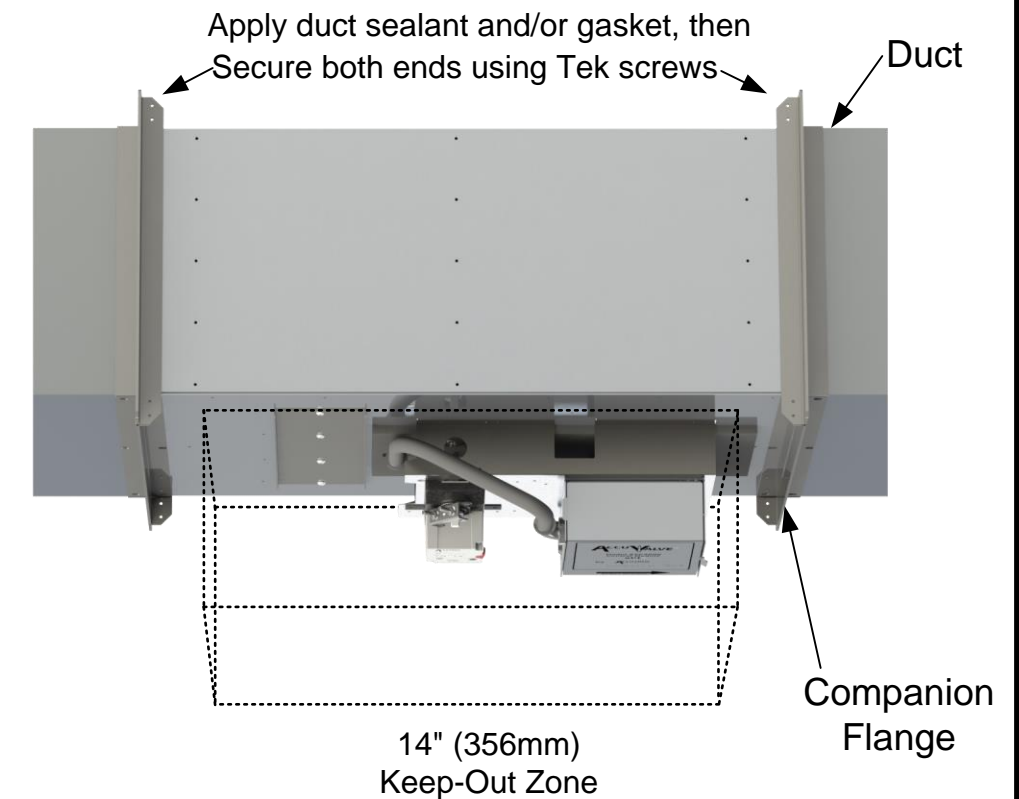

Figure 2
Flanged Valve
"Option F" Using
Companion Flanges
(Provided by Others)

Reference Rectangular
AccuValve Flange Detail
Submittal DWG



CONTROL MODULE

Note: Do not use controller enclosure as junction box for other equipment

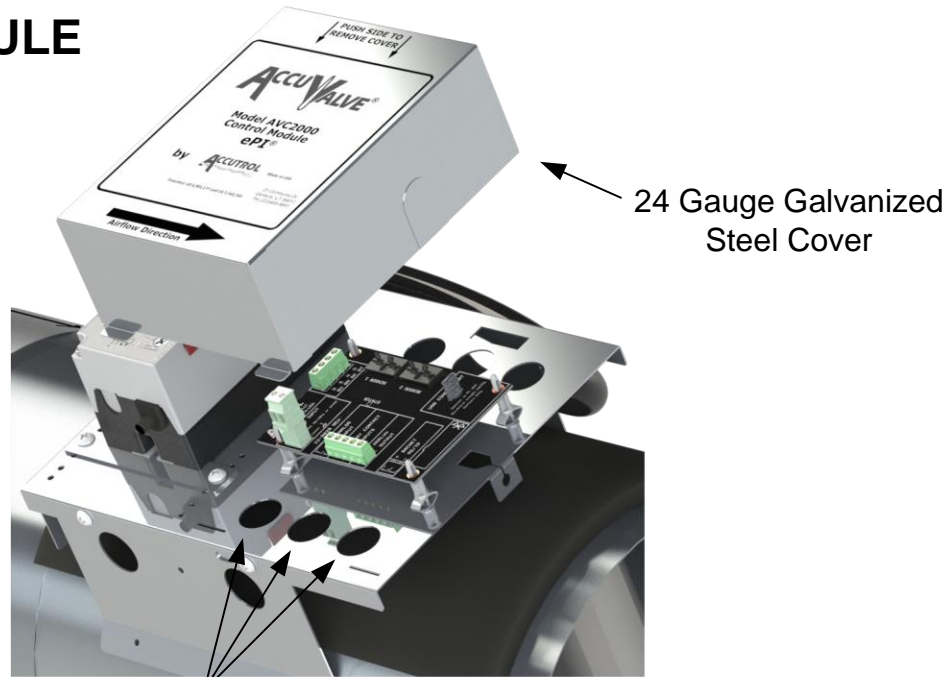

Note: If a conduit connection is required, the strain relief fitting and bushing can be removed and replaced with a .875" (22mm) conduit fitting. (Provided by Others)

Alternate Cable Entry

Wiring Instructions

1. Remove cover.
2. Route cables through the strain-relief fitting into the enclosure.
3. Connect wires to the appropriate terminals.
4. Secure terminal screws.
5. Insert the ratcheting strain relief over cable(s) and push down until snug.
6. Reinstall cover.

ELECTRICAL SPECIFICATIONS

POWER:

24VAC +/-20%, 50/60Hz. (Class 2 Power Source) 17VA

24VDC +/-10%, 9W

INPUT:

Digital Inputs: 2 dry-contact inputs

OUTPUT:

Analog Output (Software Selectable): 0-20mA, 4-20mA, 0-10V, 2-10V, 0-5V or 1-5V
V-out capable of driving 1 K-ohm load @ 10V, I-out capable of driving 1K-ohm load

CONFIGURATION PORT: USB Type C.

TERMINAL CONNECTORS:

Power: 2-Position, vertical pluggable, Wire Size range - 12-30 AWG

IO: 5-Position terminal block, Wire size range - 16-30 AWG

WIRING DIAGRAM

NOTE: Connections will vary based on application. For detailed wiring instructions, use this drawing in conjunction with the job-specific wiring diagrams.

NOTE: Analog Input and BACnet MS/TP are unavailable on the AVC2000. The artwork is still on the board but the terminals do not exist.

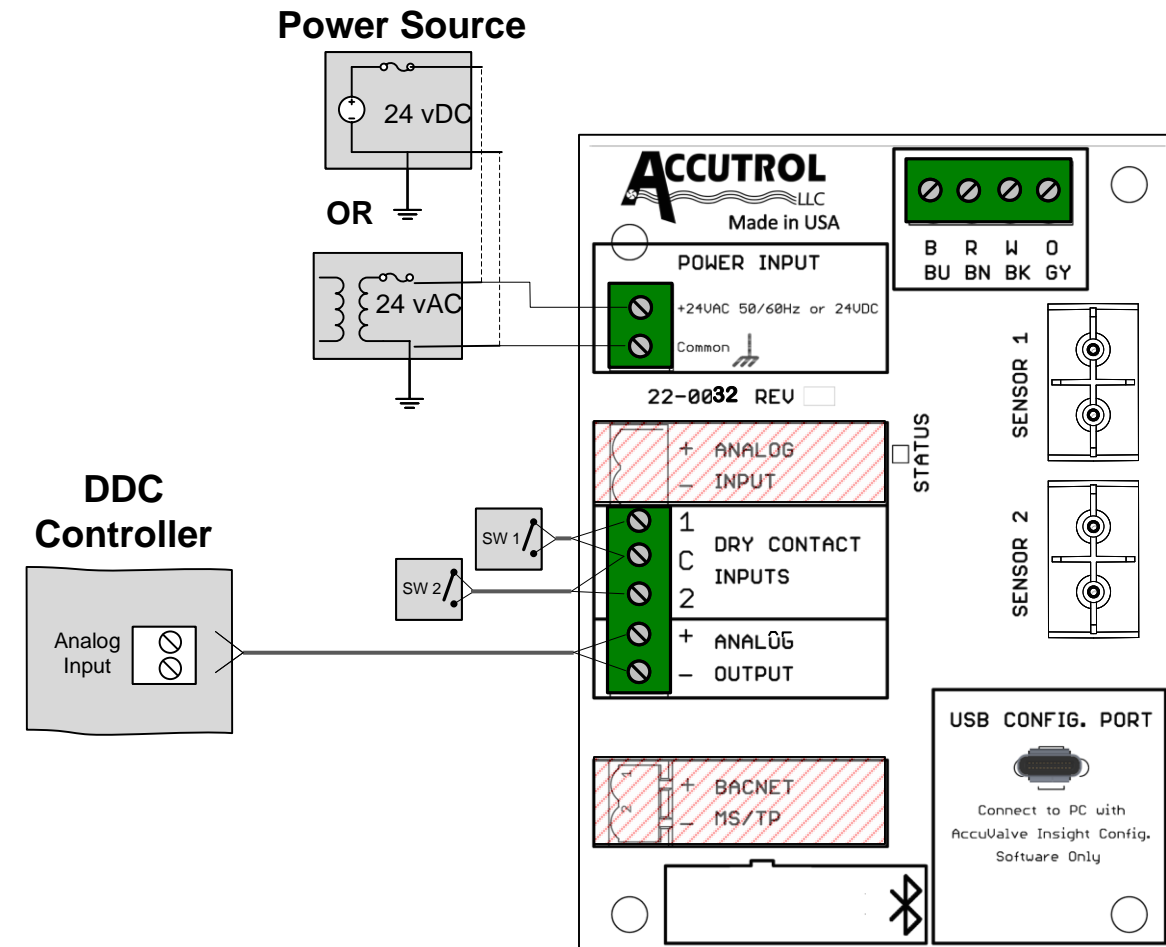

! WARNING: During installation, testing, servicing and troubleshooting of this product, it may be necessary to work with live electrical components. This work shall be performed by a licensed electrician or qualified individual who has been properly trained in handling live electrical equipment. Failure to follow all electrical safety precautions when exposed to live electrical components may result in serious injury or death.

! CAUTION: Maintain polarity if power source is used to power multiple devices otherwise equipment may be damaged.



Accutrol Representative:

SUBMITTAL DRAWING

AccuValve® Model AVC2000

THIS DOCUMENT IS SUBJECT TO CHANGE WITHOUT NOTICE. THIS DOCUMENT OR THE CONTENTS THEREOF SHALL NOT BE MODIFIED WITHOUT PRIOR WRITTEN PERMISSION BY ACCUTROL LLC.

DWG. NO:	AVC2000 SUBMITTAL DWG		
REVISION:	C	ECN:	2748
REV. DATE:	12-1-21	SHEET:	5 OF: 5