

MODEL CODE

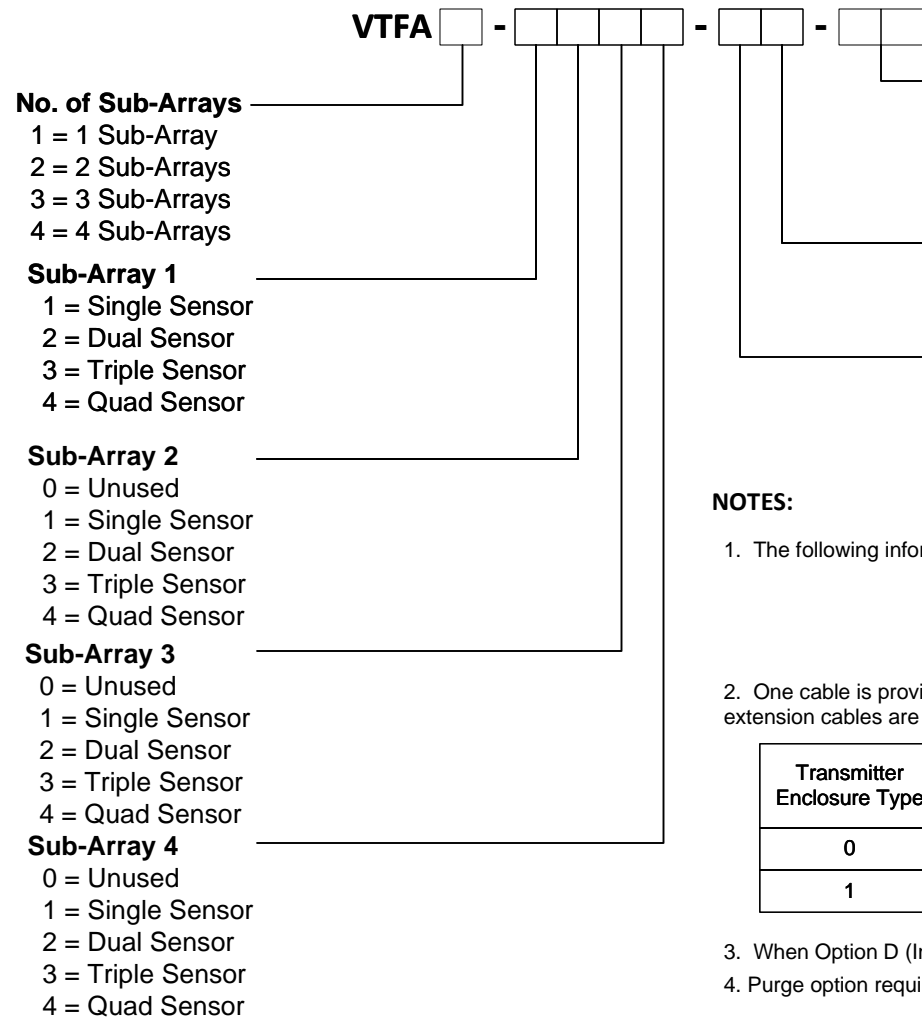

No. of Sub-Arrays

- 1 = 1 Sub-Array
- 2 = 2 Sub-Arrays
- 3 = 3 Sub-Arrays
- 4 = 4 Sub-Arrays

Sub-Array 1

- 1 = Single Sensor
- 2 = Dual Sensor
- 3 = Triple Sensor
- 4 = Quad Sensor

Sub-Array 2

- 0 = Unused
- 1 = Single Sensor
- 2 = Dual Sensor
- 3 = Triple Sensor
- 4 = Quad Sensor

Sub-Array 3

- 0 = Unused
- 1 = Single Sensor
- 2 = Dual Sensor
- 3 = Triple Sensor
- 4 = Quad Sensor

Sub-Array 4

- 0 = Unused
- 1 = Single Sensor
- 2 = Dual Sensor
- 3 = Triple Sensor
- 4 = Quad Sensor

OPTIONS

- BLANK = No Options
- B = BACnet MS/TP
- D = Internal Transmitter Display (Ref Note 3)
- P = Purge (Ref Note 4)

TRANSMITTER ENCLOSURE

- 0 = Standard
- 1 = NEMA 4X

CABLE LENGTH (Ref Note 2)

- 1 = 25' (7.6m)
- 2 = 50' (15.2m)

NOTES:

1. The following information shall be provided with order:
 - Device Tag Number
 - Analog Output Full Scale Range
 - Analog Output Signal Type
 - Fan Inlet Diameter
 - (Reference Figures on Following Pages)
 2. One cable is provided with each probe. Max length of Outdoor Rated cable is 50'. Outdoor-rated 50' extension cables are sold separately.
- | Transmitter Enclosure Type | Cable Terminations | |
|----------------------------|--------------------|------------------------|
| | Transmitter End | Sensor Electronics End |
| 0 | Standard RJ45 | Weatherproof RJ45 |
| 1 | Weatherproof RJ45 | Weatherproof RJ45 |
3. When Option D (Internal Transmitter Display) is selected, the Remote Display cannot be used.
 4. Purge option requires connection to 20 psi clean and dry instrument air supply.

SPECIFICATIONS

PERFORMANCE

- Accuracy**
- Individual Sensors +/-2% of reading
- System Accuracy +/-5% of reading (installed accuracy expected when installation meets guidelines)
- Repeatability** +/- 0.1% of reading
- Sensor FS Range** Factory Default is 12,000 FPM (60.69 m/s) (software configurable)

ENVIRONMENTAL

- Operating Temperature**
- Sensor -40° to 165° F (-40° to 74° C)
- Transmitter -20° to 150° F (-29° to 66° C)
- Display (optional) -4° to 158° F (-20° to 70° C)
- Storage Temperature** -22° to 165° F (-30° to 74° C)
- Humidity** 0 to 95% (non-condensing)

ELECTRICAL

- Input Power** 24VAC +/- 20% 50-60Hz, 2.4 VA with no options, 4.8 VA with display & BACnet options
24VDC +/-10%, 1 W with no options, 3 W with display & BACnet options
- Inputs** 4 Sensor Input Channels with up to 4 Sensors per Input (16 Sensors Max)
- Output** 0-20mA, 4-20mA, 0-10v, 2-10v, 0-5v or 1-5v (software configurable)
12-bit Resolution, Capable of driving 1K ohm load
- Configuration Port** USB 2.0, Isolated, USB C Connector
- USB Power Switch** Selects alternate power source for configuration when main power is not available
Draws 5v power from USB configuration port
- Status Indicators** LED Status Indicators for; Power, Output, Configuration Port, Power Source Switch, Sensor Input Channel 3 and 4, Display and BACnet Communications
- I/O Terminal Block** 3 position vertical pluggable screw terminal block, screw access on top, 12-30 AWG
- Cables**
- Standard Outdoor rated shielded cables with watertight plug on sensor end
- Optional NEMA 4X Transmitter; IP67 Outdoor rated shielded cables with watertight plug on both ends
- Network Com Port (Optional)** EIA 485 2-wire BACnet MS/TP
Galvanically Isolated
Data Rates 9600, 19200, 38400, 76800 and 115200
1/8 Unit Load Receiver Input Impedance
Network bias and EOL Termination not provided within the Transmitter
- Display (Optional)** Remote mount or transmitter mount
Liquid Crystal Display, 2 lines x 8 characters with white LED backlight
Includes USB Configuration Port

MATERIALS OF CONSTRUCTION

- Sensor Enclosures** Polycarbonate Plastic UL94 V-0
- Mounting Hardware**
- Sensor Rivet Nuts Neoprene rubber-coated brass with zinc plated steel screws
- Conduit Clamp Zinc-plated steel over EPDM rubber with stainless steel Tek-screw
- Sensor Tubing** Ether-based polyurethane
- Flexible Conduit** UV resistant flexible PVC, VW-1 Flammability Rating
- Conduit Fittings** Nylon 6/6, UL94 V-2
- Enclosures** Transmitter: Aluminum Alloy 5052-H32, 16 Gauge
Sensor Electronics: NEMA 4X (IP66) Polycarbonate Plastic UL94 V-0
Optional Transmitter: NEMA 4X (IPX6) Polycarbonate Plastic UL94 V-0

EMC AND SAFETY

- Emissions** EN 55011:2009+A1:2010, FCC Part 15:2017, ICES-003 Issue 6, EN61000-3-2:2014, EN61000-3-3:2013
- Immunity** EN61326-1:2013, EN61000-4-2:2009, EN61000-4-3:2006+A1:2008+A2:2010, EN61000-4-4:2012, EN61000-4-5:2006, EN61000-4-6:2009, EN61000-4-8:2010, EN61000-4-11:2004
- Safety** EN61010-1:2010

Model Shown Below: VTFA2-1100-10-P

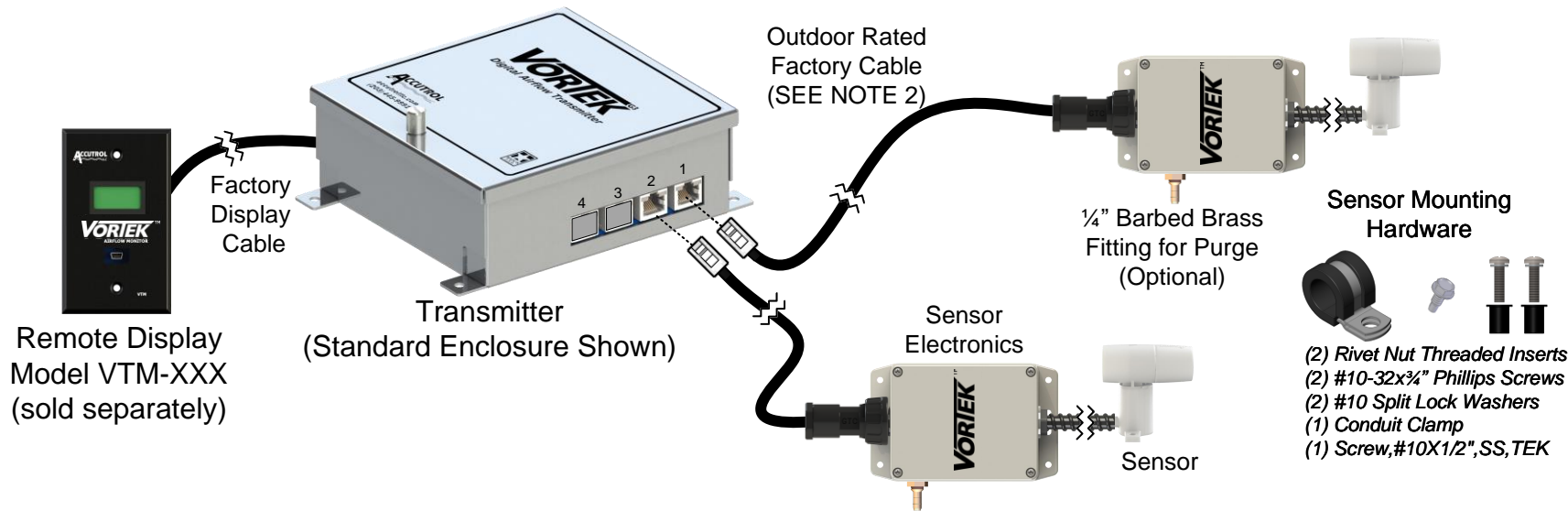

Accutrol Representative:

SUBMITTAL DRAWING

VorTek Fan Array Model VTFA

THIS DOCUMENT IS SUBJECT TO CHANGE WITHOUT NOTICE. THIS DOCUMENT OR THE CONTENTS THEREOF SHALL NOT BE MODIFIED WITHOUT PRIOR WRITTEN PERMISSION BY ACCUTROL LLC.

DWG. NO:	VTFA SUBMITTAL		
REVISION:	P	ECN:	2874
REV. DATE:	2-22-23	SHEET:	1 OF 4

SENSOR INSTALLATION

CROSS SECTION VIEW

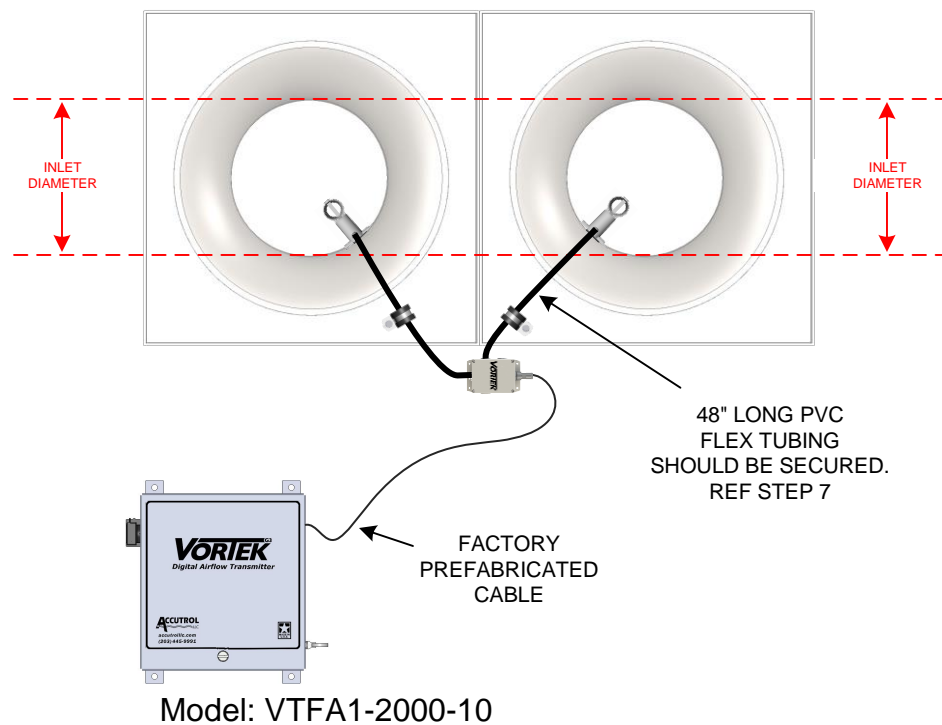
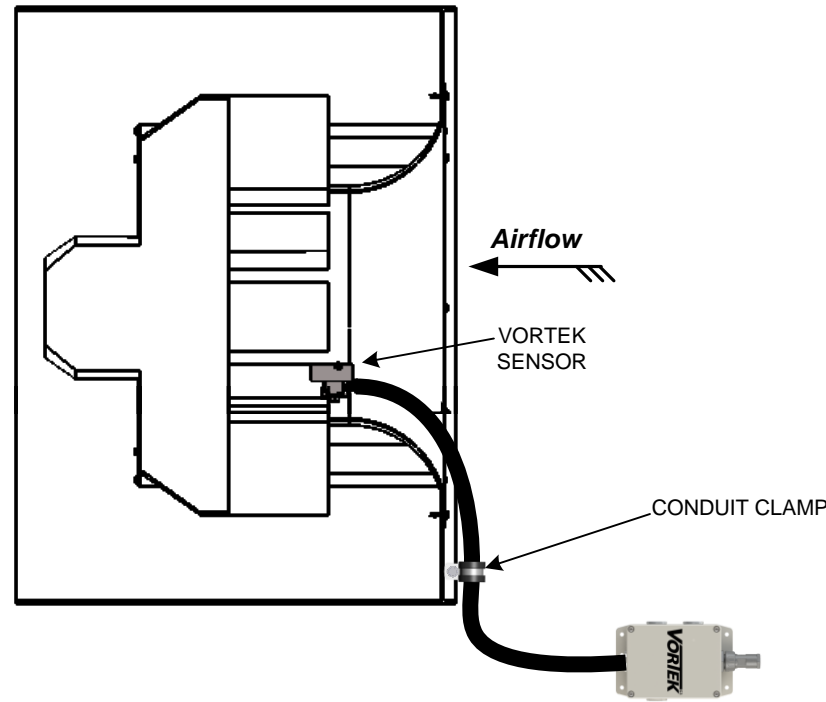

⚠ CAUTION: Only use the mounting hardware provided with the sensors and follow the instructions below, otherwise damage to the fan may result. If hardware is missing contact the factory.

⚠ WARNING: Use safety glasses and cut-resistant gloves when installing sensors. Verify the circuit providing power to the fan is turned off and there is no power at the fan motor.

MOUNTING HARDWARE PROVIDED WITH EACH SENSOR:

- (2) #10-32 Well-Nuts with Threaded Inserts
- (2) #10-32 x 3/4" Long Phillips Screws
- (2) #10 Split Lock Washers
- (1) Drilling Template Label
- (1) Conduit Clamp
- (1) Screw, #10x1/2",SS,TEK

TOOLS REQUIRED:

- Drill with a 3/8" Drill Bit
- #2 Phillips Screwdriver with Torque Indicator

1. Position the drilling template label into the throat of the fan inlet bell (smallest diameter) with airflow direction indicator facing towards the fan blades. Verify the fan blades will not come in close contact with the sensor and there are no obstructions in front of the sensor.
2. Drill a hole at each location using a 3/8" diameter drill bit.

①

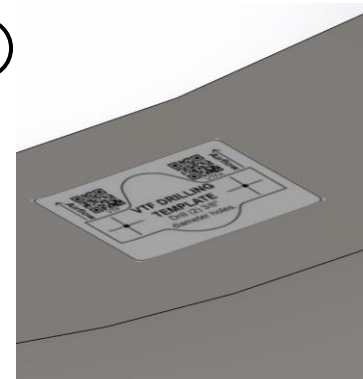

②

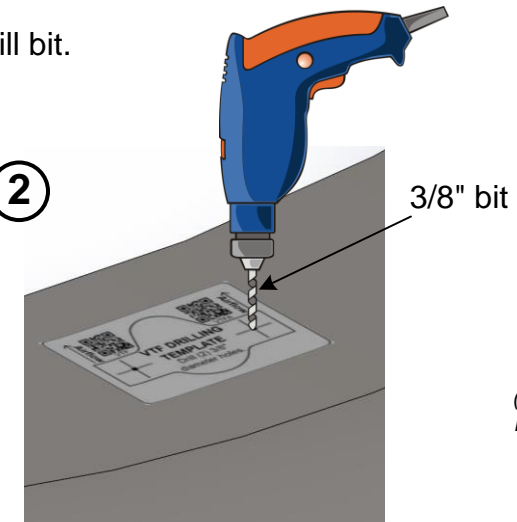

③ ④ ⑤

(2) #10-32 x 3/4" Phillips Screws
(2) #10 Split Lock Washers

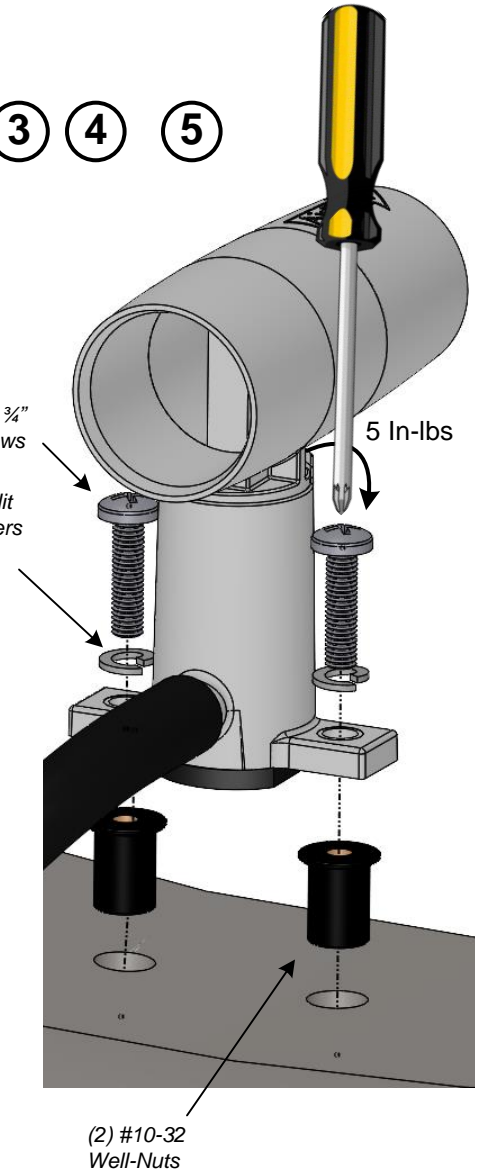

3. Insert the 2 well-nuts into the 3/8" diameter holes.
4. Place the sensor into the fan inlet bell and align the two holes in mounting bracket with the two well-nuts. Verify the airflow direction indicator on the sensor is pointing towards the fan blades.
5. Secure the sensor in place using mounting hardware supplied. Tighten the two screws to 5 inch-pounds.
6. For applications with two sensors, select mounting location on the opposite side of inlet bell for the second sensor and repeat above steps.
7. In addition to serving as a signal conduit, the flexible tubing also provides a mechanical safety connection to prevent the sensor from getting pulled into the fan if it becomes disengaged. Pull the flexible conduit away from the fan inlet and secure it to a surface using the provided Conduit Clamp so it is not in the air stream and there is no slack in the tubing between the sensor and mounting hardware. Secure the Sensor Electronics Enclosure in place out of the airstream.
8. For dual inlet applications, repeat above steps for other inlet side.

TRANSMITTER INSTALLATION

1. Select an easily accessible location to install the transmitter within the range of the sensor cables that have been provided. Provide clearance to remove the cover and easily access the connectors and field connections.
2. Using the four 0.20" diameter holes located on the transmitter enclosure, secure the transmitter to mounting surface using (4) #8 or #10 Pan Head Screws. For sheet metal mounting surface, use sheet metal or tek screws, for plywood surface use coarse thread wood screws, for drywall surface, use drywall anchors with the appropriate screws.
3. Connect each sensor to the corresponding sensor input channel on the transmitter using the cables provided (Reference Figure 1)

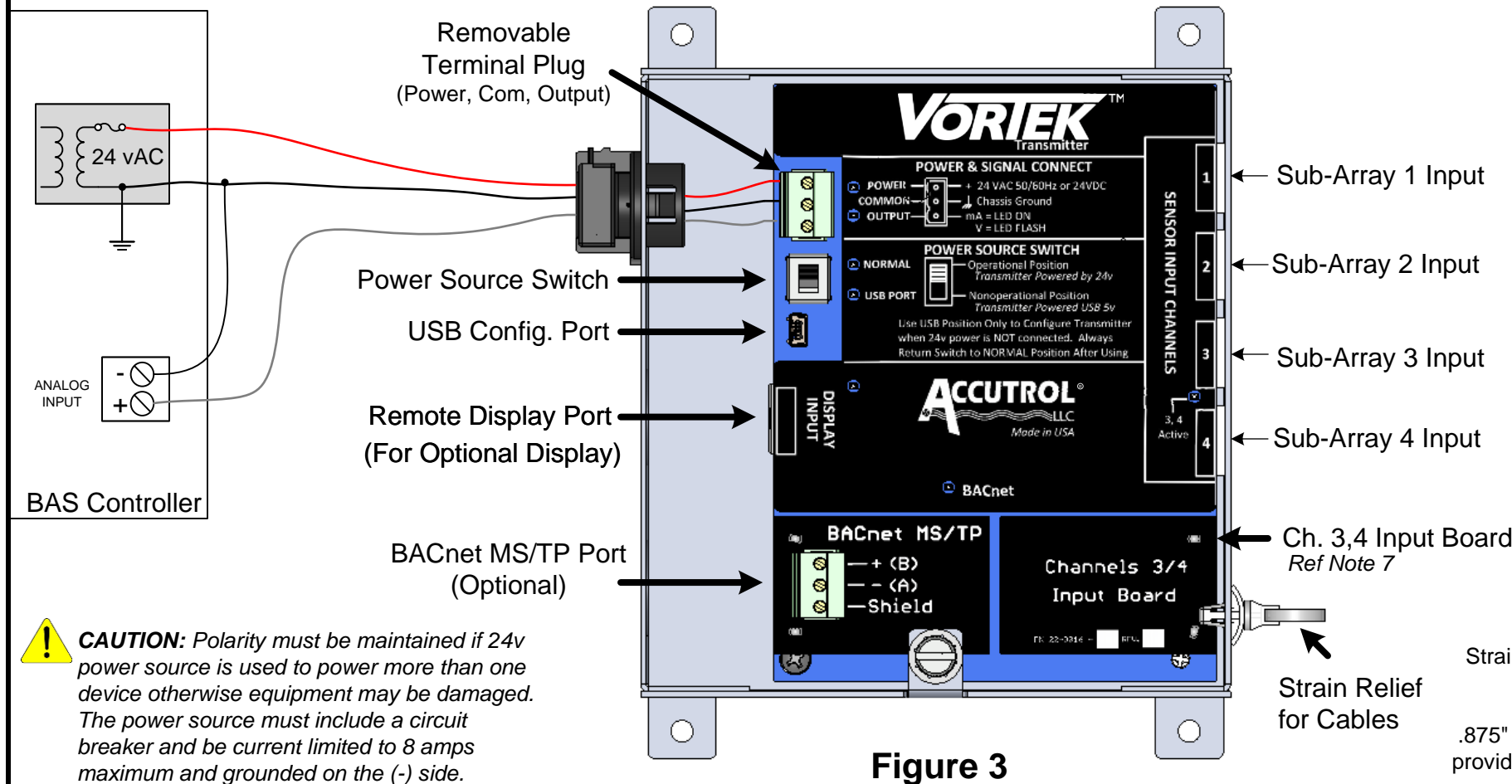

CAUTION: Polarity must be maintained if 24v power source is used to power more than one device otherwise equipment may be damaged. The power source must include a circuit breaker and be current limited to 8 amps maximum and grounded on the (-) side.

TRANSMITTER WIRING

1. Loosen the thumb screw located on the transmitter enclosure cover and remove cover.
2. Run 3-conductor cable from the field controller to the transmitter through the strain relief fitting.
3. Remove the terminal block from the power & signal header, loosen the three screws and terminate the power, common and output signal wires in the terminal block per markings.
4. Tighten the terminal block screws, verify wires are secure and reconnect to the header.
5. If BACnet is required; run BACnet MS/TP cable into enclosure, remove terminal block from BACnet header and terminate the BACnet wires in the appropriate terminals. Tighten the terminal block screws, verify wires are secure and reconnect to header.
6. If Remote Display is required; remove knock-out located directly in line with the Display Port, install strain relief fitting into .875" dia. hole, run the factory cable provided with the Remote Display into the enclosure and plug cable into the Display Input Port.
7. The channel 3,4 input board is required for applications that have 3 or 4 sub-arrays. Applications with 1 or 2 sub-arrays do not require this board.

Figure 1
Model: VTFA 2-2200-10-00

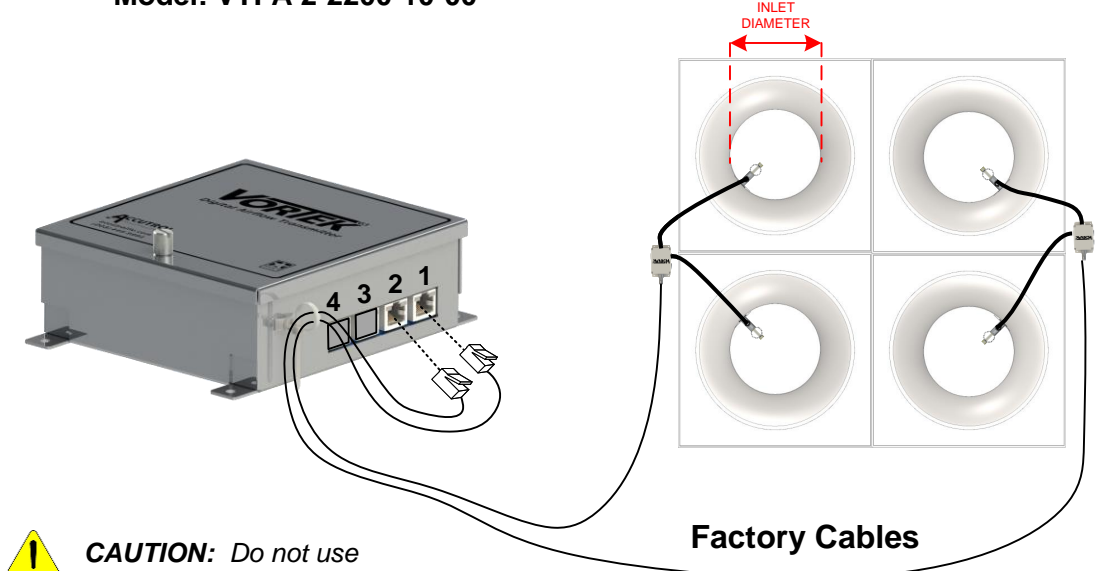

CAUTION: Do not use transmitter enclosure as a junction box. Only wires terminating on the transmitter board should enter the enclosure.

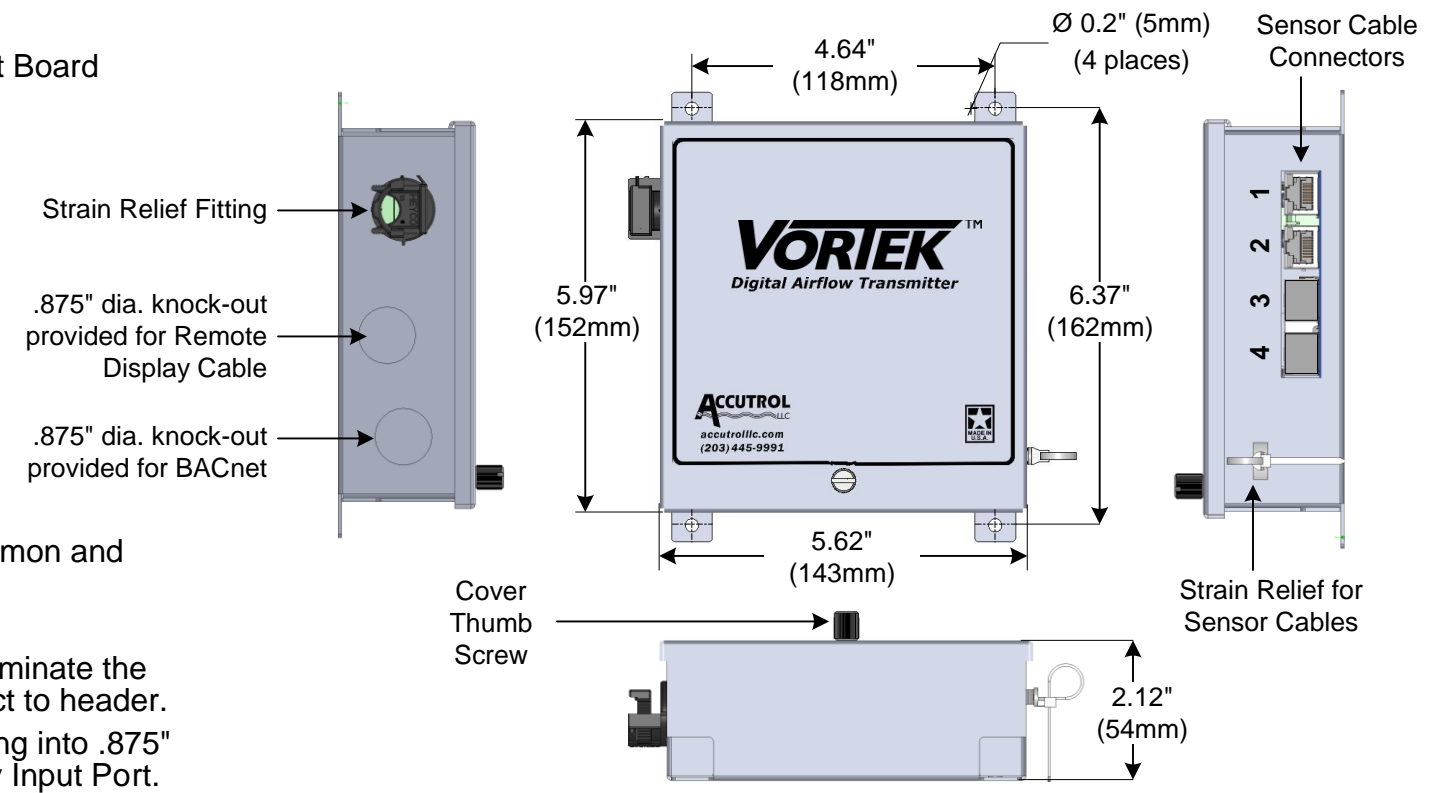
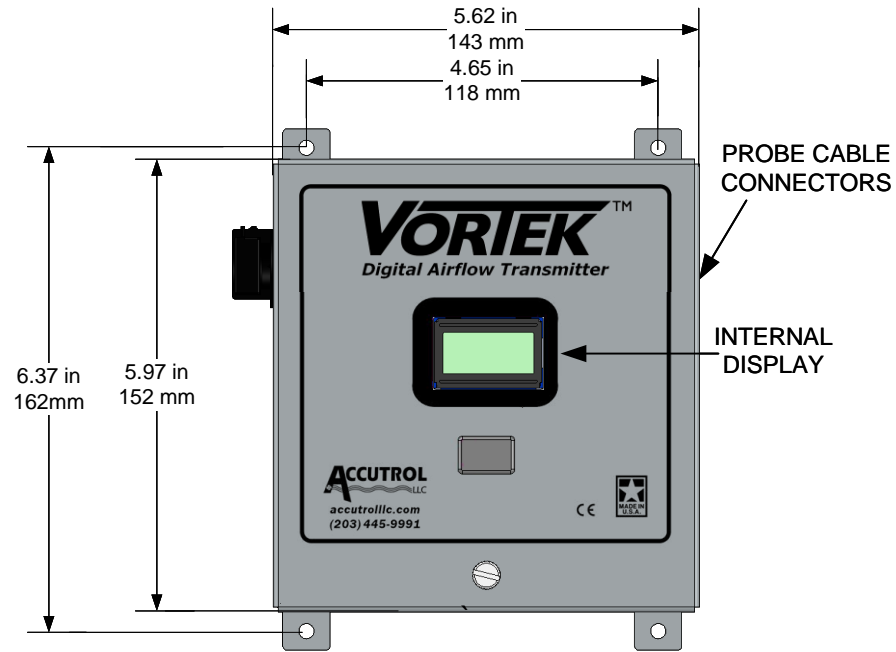

Figure 2

OPTIONS

TRANSMITTER WITH OPTIONAL DISPLAY



NEMA 4X TRANSMITTER WITH OPTIONAL DISPLAY

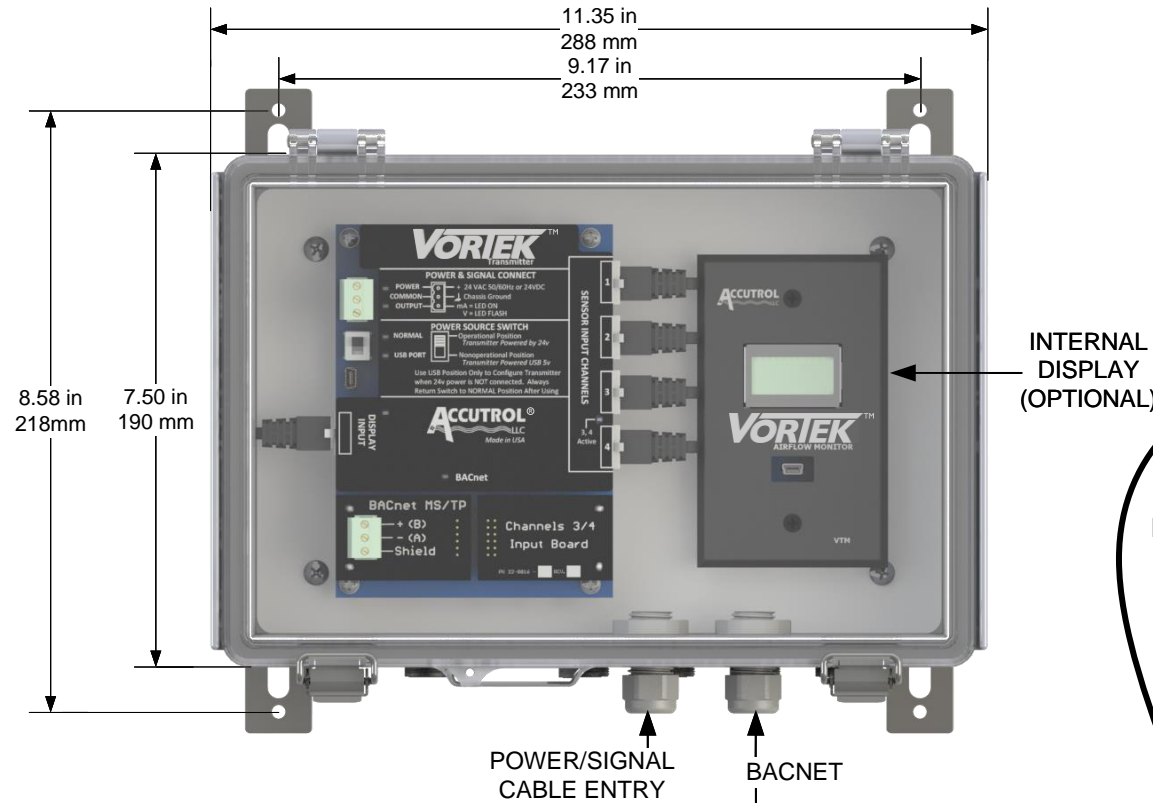

NEMA 4X SENSOR WITH OPTIONAL PURGE

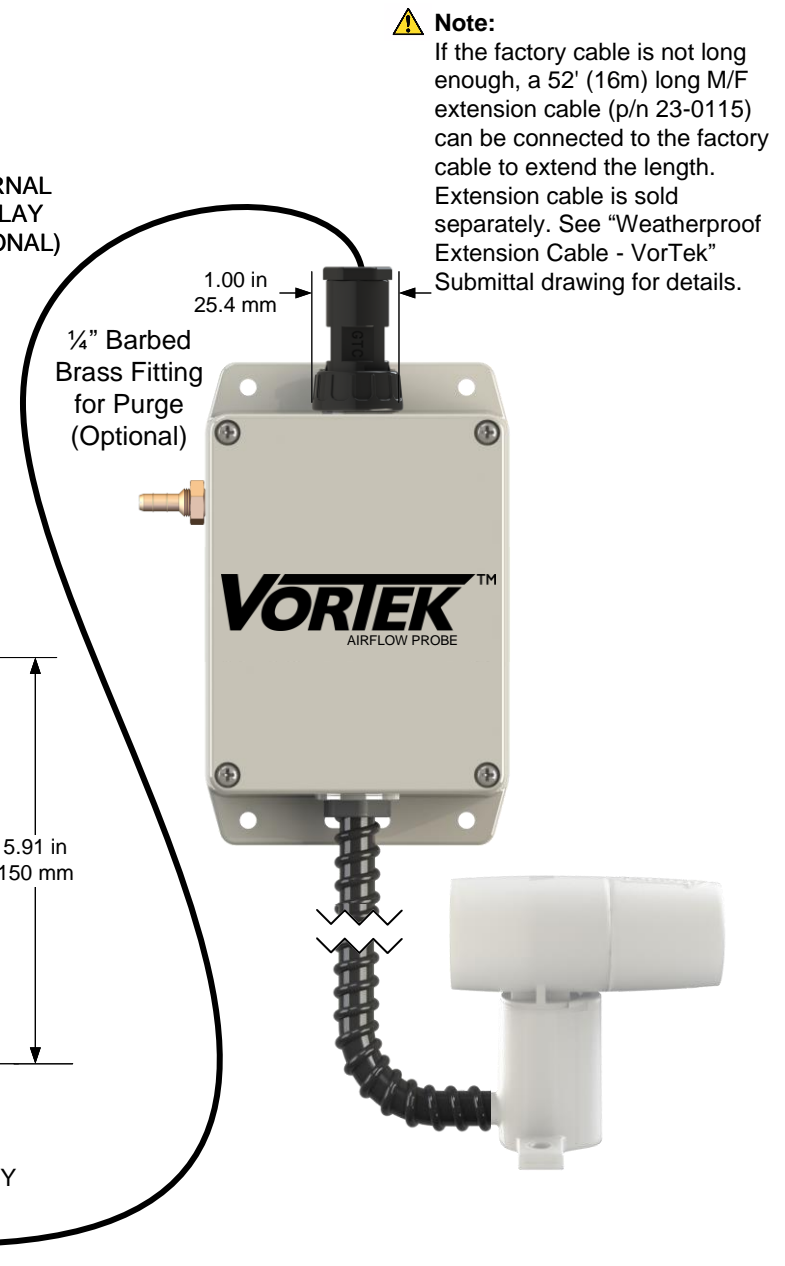

Note:
If the factory cable is not long enough, a 52' (16m) long M/F extension cable (p/n 23-0115) can be connected to the factory cable to extend the length. Extension cable is sold separately. See "Weatherproof Extension Cable - VorTek" Submittal drawing for details.

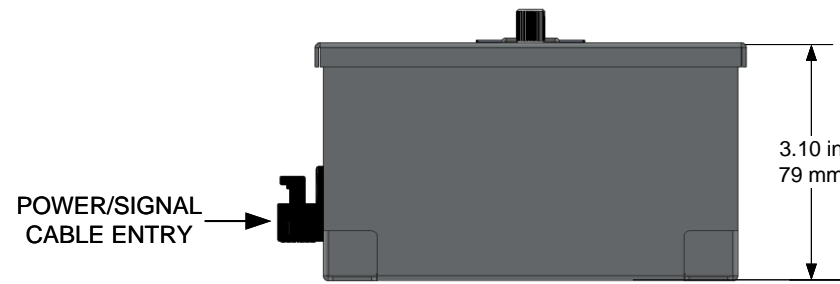

EXTERNAL DISPLAY CONNECTOR (NOT PROVIDED WITH OPTIONAL INTERNAL DISPLAY)

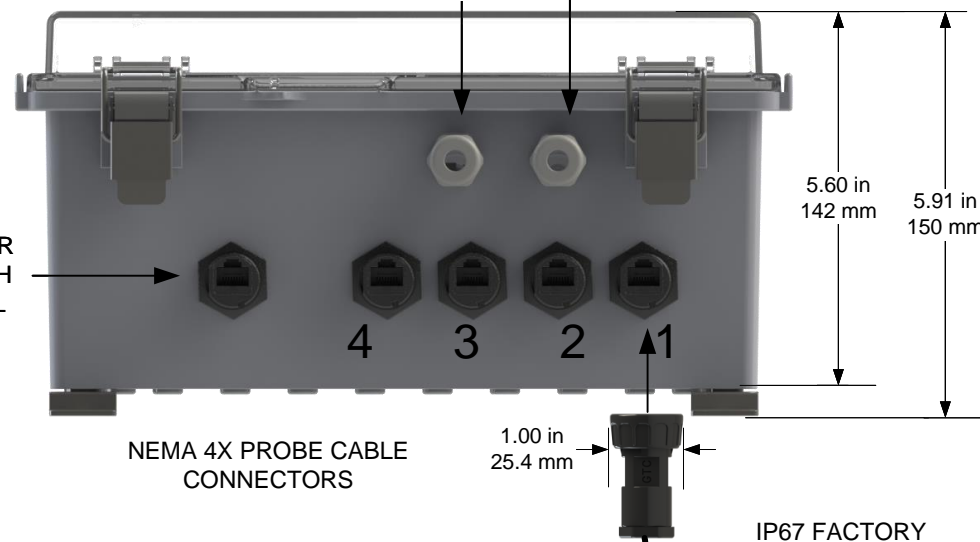

Note: If cable is to be run through conduit, be sure to size the conduit to accommodate the cable connectors.