

APPLICATION

The 20-0010 actuator is used for AccuValve® applications that require high-speed response over a control range of 0 to 10 volts and will “fail in either open or closed position” when power is removed.

DIMENSIONS

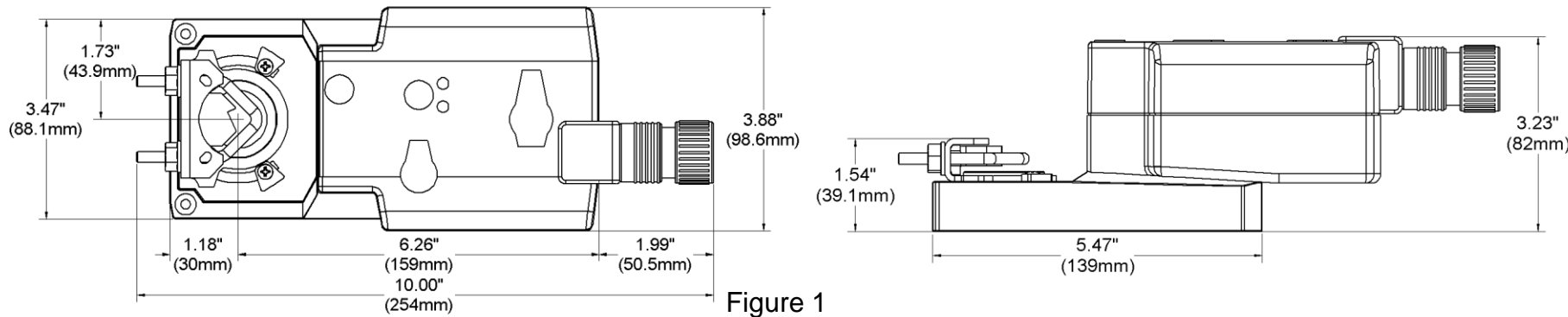

Figure 1

INSTALLATION

Each actuator is installed, configured and tested on the AccuValve® prior to shipping from the Accutrol factory. The following instructions are provided as a reference for replacing an actuator in the field.

Parts Required

- (1) Actuator, PN 20-0010
- (2) Screws, PN 17-0246 (#8-32 x 5/16)

Tools Required

- 10mm wrench
- #2 Phillips Head Screw Driver

Reference Figure 2

1. Slide actuator V-clamp over the AccuValve drive shaft.
2. Align the flat of the drive shaft with the flat of the shaft coupling.
3. Insert the two screws into the holes located on the corners of the actuator base and align with the two threaded holes located on the valve mounting bracket.
4. Secure the actuator to the bracket by tightening the 2 screws.
5. Secure the actuator coupling to the AccuValve drive shaft by tightening the (2) 10mm nuts on the v-clamp. Secure each nut evenly and torque each nut to 6 to 7 ft-lbs.

⚠ Any time clutch is pressed, actuator must be re-adapted with power applied.

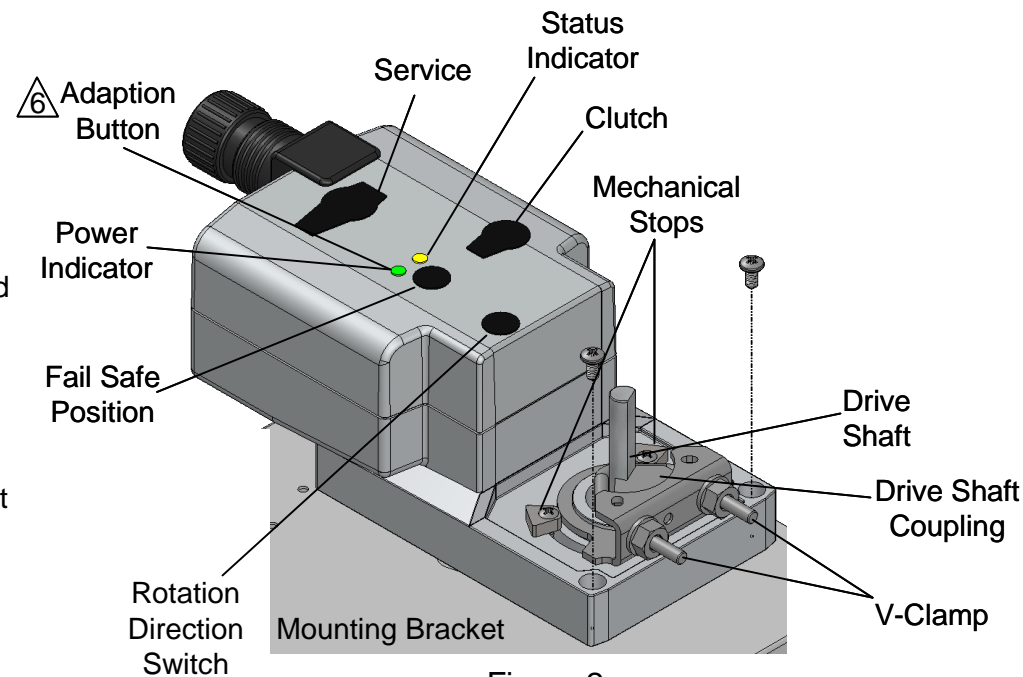

Figure 2

TECHNICAL DATA

ELECTRICAL

Power Supply	24 VAC +/- 20% 50/60 Hz, or 24 VDC +/- 10%
Power Consumption:	3 W nominal, 11 W max
Transformer Sizing:	22 VA (Class 2 power source)
Electrical Connection:	Cable, 3' Plenum, NEMA 2 (IP 54), 4-Conductor, 18 GA
Overload Protection:	Electronic, throughout range of rotation
Control Signal:	0.5 to 10V
Feedback Signal:	0.5 to 10V
Input Impedance:	100K ohm
Resolution:	47.5mV response to control signal 76mV response to control signal change of direction

MECHANICAL

Angle of Rotation:	Factory-set with mechanical stops (approximately 45°)
Running Time:	2 seconds full stroke
Torque:	54 in-lb (6.1Nm)
Direction of Rotation:	Reversible with switch
Fail Safe Position:	Adjustable with dial from 0 to 100%
Manual Override:	External push button
Weight:	2.4 lbs. (1.1 kg)
Noise Level:	< 60 dBA
Housing Material:	UL94-5VA

ENVIRONMENTAL

Humidity:	5 to 95% RH non-condensing (EN 60730)
Operating Temperature:	-22°F to 122°F (-30°C to 50°C)
Storage Temperature:	-40°F to 176°F (-40°C to 80°C)
Housing:	NEMA 2, IP54, UL enclosure type 2

AGENCY LISTINGS & QUALITY STANDARDS

cULus acc. To UL 60730-1A/-2-14
CAN/CSA E60730-1:02
CE acc. To 2004/108/EEC and 2006/95/EC
QS ISO 9001

SERVICE

No Maintenance Required

WIRING

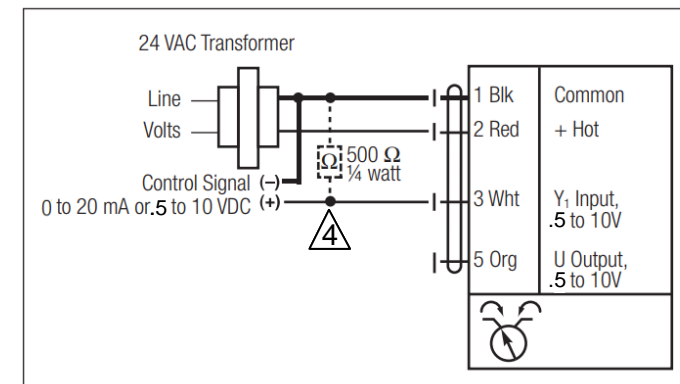

Figure 3

1. Provide overload protection and disconnect as required.

2. Actuators may be connected in parallel if not mechanically mounted to the same shaft. Power consumption and input impedance must be observed.

3. Actuators may also be powered by 24 VDC.

⚠ 500Ω resistor is only required when using current control signal