

MODEL CODE

NUMBER OF ROOM SENSOR KITS

- 1 = 1 Room Sensor Kit
- 2 = 2 Room Sensor Kits
- 3 = 3 Room Sensor Kits
- 4 = 4 Room Sensor Kits

SENSOR RANGE

- 1 = -0.1" TO +0.1" wc

DISPLAY TYPE

- 1 = 7" Touch Screen



OPTIONS

- BLANK = No Options
- M = BACnet MS/TP
- W = Wireless Bluetooth

DISPLAY CABLE LENGTH

- 1 = 25' (7.6m)
- 2 = 50' (15.2m)
- 3 = 75' (22.9m)
- 4 = 100' (30.5m)

SYSTEM DIAGRAM

Single Room Application Model: ISO1111

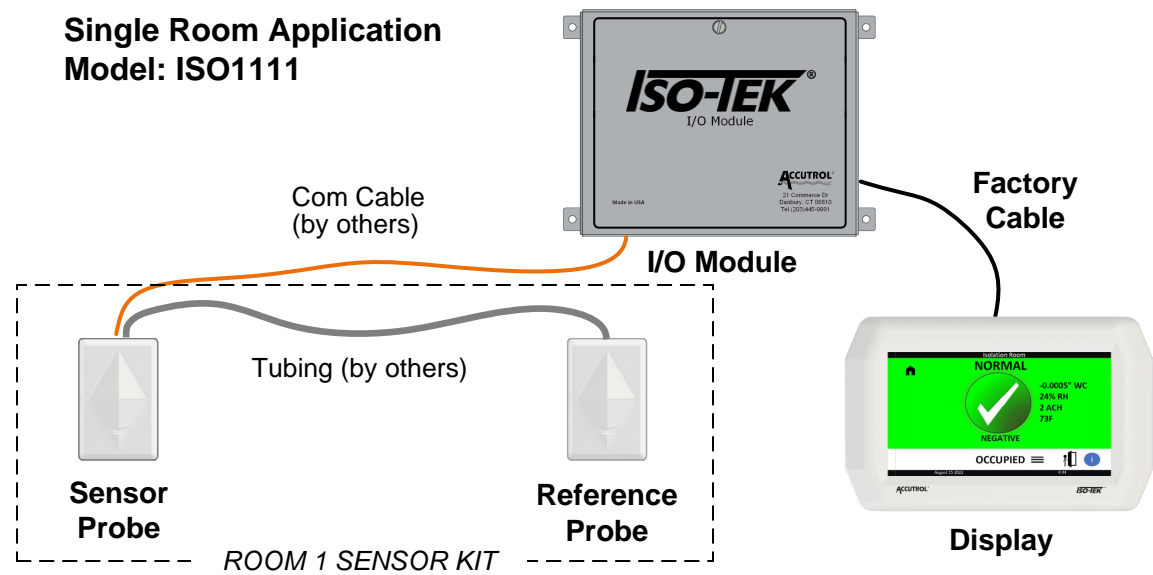

NOTES:

1. Reference Sheet 3 for tubing details.
2. Reference Sheet 4 for wiring details.

Multi-Room Application Model: ISO2111

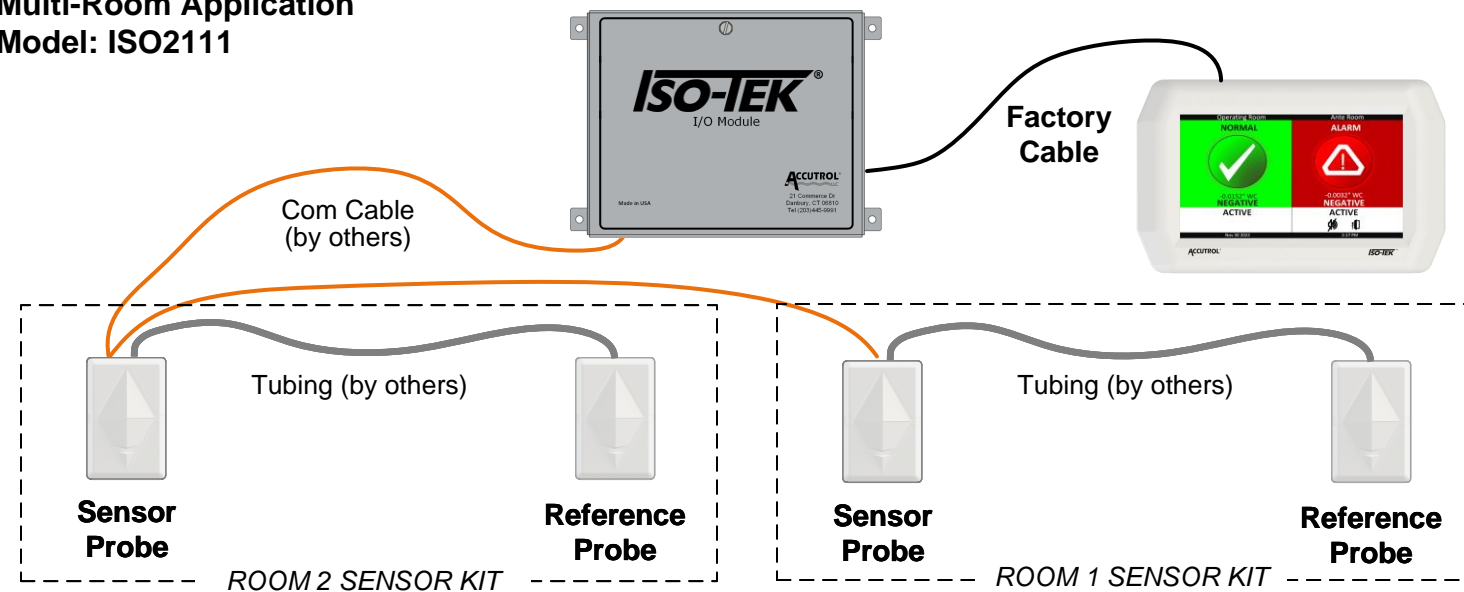

SPECIFICATIONS

PRESSURE SENSOR

Pressure Range	+/- 0.100"wc (+/- 25Pa)
Pressure Measurement Resolution	0.0000335"wc (0.00083Pa)
Zero Pressure Offset Accuracy	Typical: +/- 0.00016"wc (+/- 0.04Pa) Max: +/- 0.0004"wc (+/- 0.1Pa)
Span Accuracy	Typical: +/- 0.75% of reading Max: +/- 1.5% of reading
Thermal Effects -4 to 185 deg F (-20 to 85 deg C)	Offset: Max +/- 0.0004"wc (+/- 0.1Pa) Span: Typical +/- 0.2% of reading per 18 deg F (10 deg C) Max +/- 0.5% of reading per 18 deg F (10 deg C)
Static Error Band	+/- 3% of reading Note: Includes linearity, hysteresis, and repeatability
Long Term Stability	+/- 0.00008"wc (+/- 0.02Pa) per year max
Status Indicators	Green LED to indicate status
Connections	4-pos. screw terminal Note: connect to IO Module using Windy City Wire # 042003 or equivalent
Operating Temp Range	-4 to 176 deg F (-20 to 80 deg C)
Storage Temp Range	-40 to 185 deg F (-40 to 85 deg C)
Humidity	0 to 95% noncondensing

DISPLAY (Local HMI)

Display Type	7" LCD-TFT Resistive touch display with LED backlight
Color	RGB 65K colors
Active Area	6.49" x 3.937" (164.9mm x 100mm)
Resolution	800 x 480 pixel
Speaker	audible notifications, 550~18KHz, 83dBA SPL @ 1W/0.5M
Connections	RJ-45 connector Note: connect to IO Module using factory-provided cable only
Configuration Port	USB 2.0, Isolated, Type C Conn., connect PC with Iso-Tek Insight
Operating Temp Range	-4 to 150 deg F (-20 to 65 deg C)
Storage Temp Range	-40 to 185 deg F (-40 to 85 deg C)
Humidity	10 to 90% noncondensing

IO MODULE

System Input Power	24VAC +20/-10%, 22VA, 50-60Hz or 24 VDC +/- 10%, 10W Max Power requirements for fully loaded system: 15VA or 9 Watts
Relay Outputs	2 Independent SPST Relay Contacts (Software Configurable) Contact Rating: 2A @ 30VDC, 0.5A @ 60VDC, 0.3A @ 125VAC
Analog Outputs	2 Analog Outputs for Room Pressure (Software Configurable) 0-5v, 1-5v, 0-10v, 2-10v, 0-20mA or 4-20mA capable of driving 1 K-ohm load
Door Switch Input	Dry Contact Input for Primary Room Door Switch (software configurable)
Accutrol Sensor Port	5-pos. pluggable screw terminal Note: connect to Pressure Sensor Network using Windy City Wire # 042003 only
Accutrol Display Port	RJ-45 connector Note: Connect to Display Module using factory-provided cable only
BACnet MS/TP (Optional)	EIA 485 2-wire, BACnet MS/TP, Galvanically Isolated 1/8 unit load transceiver impedance Full Master Node State Machine Data Rates 9600, 19200, 38400, 76800 and 115200 MAC address is software configurable
BACnet IP (Optional)	Future
Status Indicators	LED Indicators for Power, Pressure Sensor, Display, BACnet, & Bluetooth
I/O Terminal Blocks	Removable Vertical Plugs, Wire Size Range 12-30 AWG
Bluetooth (Optional)	Bluetooth Version 4.2 or later, connect to PC with Iso-Tek Insight
Operating Temp Range	-20 to 176 deg F (-29 to 80 deg C)
Storage Temp Range	-40 to 185 deg F (-40 to 85 deg C)
Humidity	0 to 95% noncondensing

COMPLIANCE

RoHS, UL94-V0



Accutrol Representative:

SUBMITTAL DRAWING



THIS DOCUMENT IS SUBJECT TO CHANGE WITHOUT NOTICE.
THIS DOCUMENT OR THE CONTENTS THEREOF SHALL NOT BE MODIFIED WITHOUT PRIOR WRITTEN PERMISSION BY ACCUTROL LLC.

DWG. NO:	Iso-Tek SUBMITTAL		
REVISION:	F	ECN:	2935
REV. DATE:	12-11-23	SHEET:	1 OF 4

DIMENSIONS

Display Module

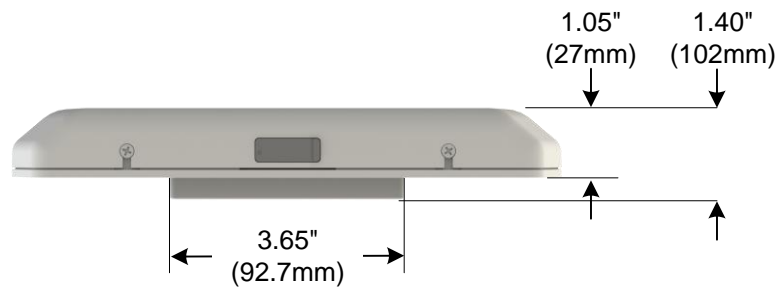
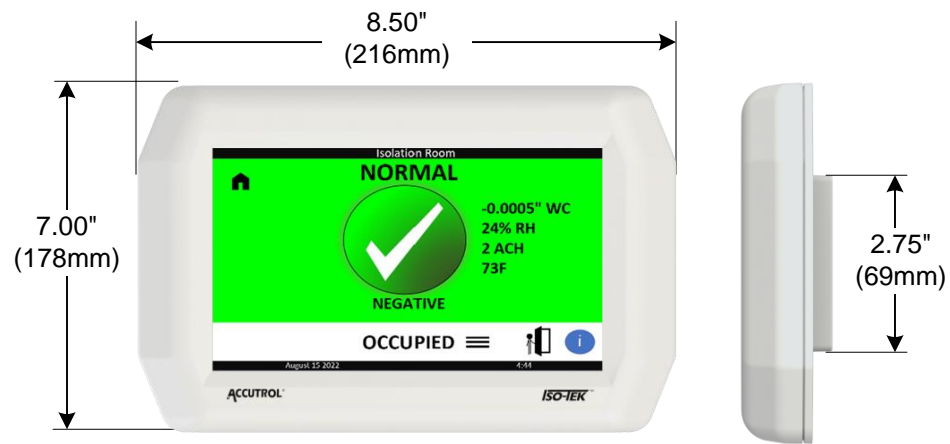

Display Cable

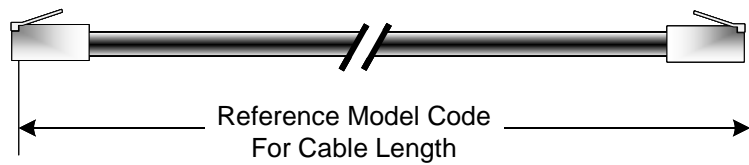

IO Module

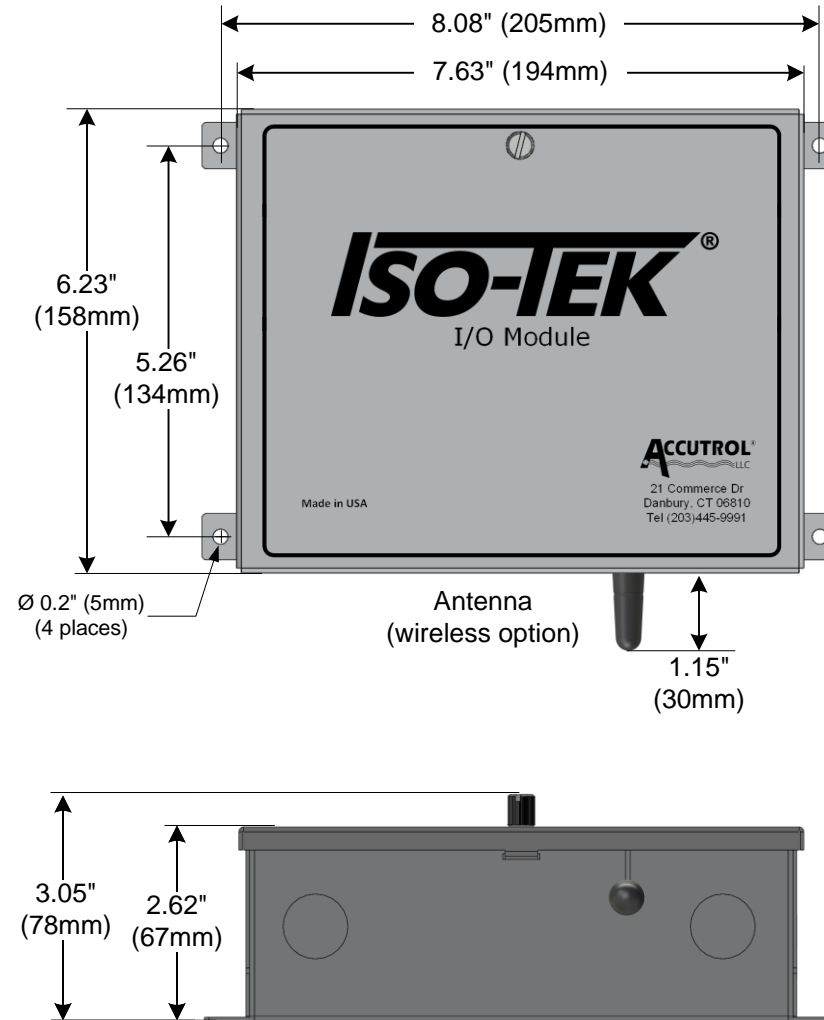

Sensor Probe

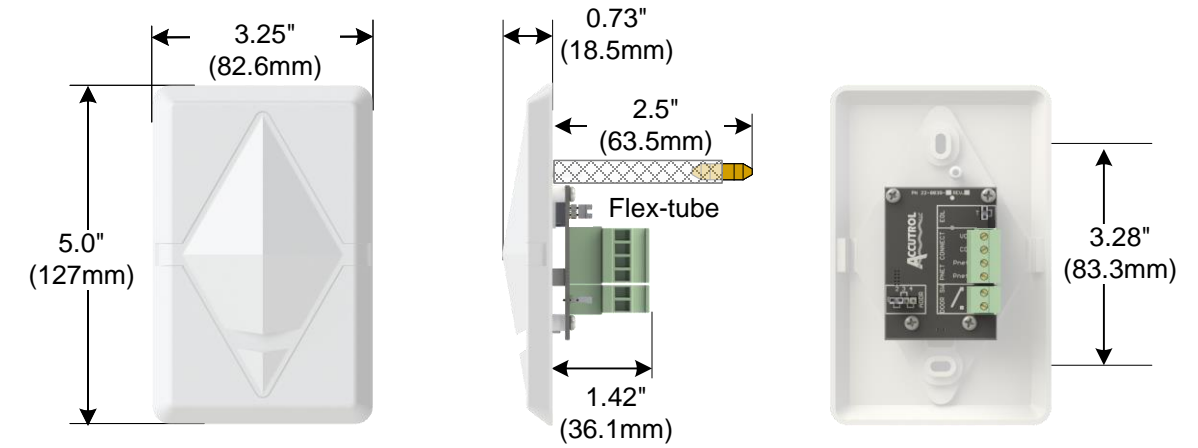

Reference Probe

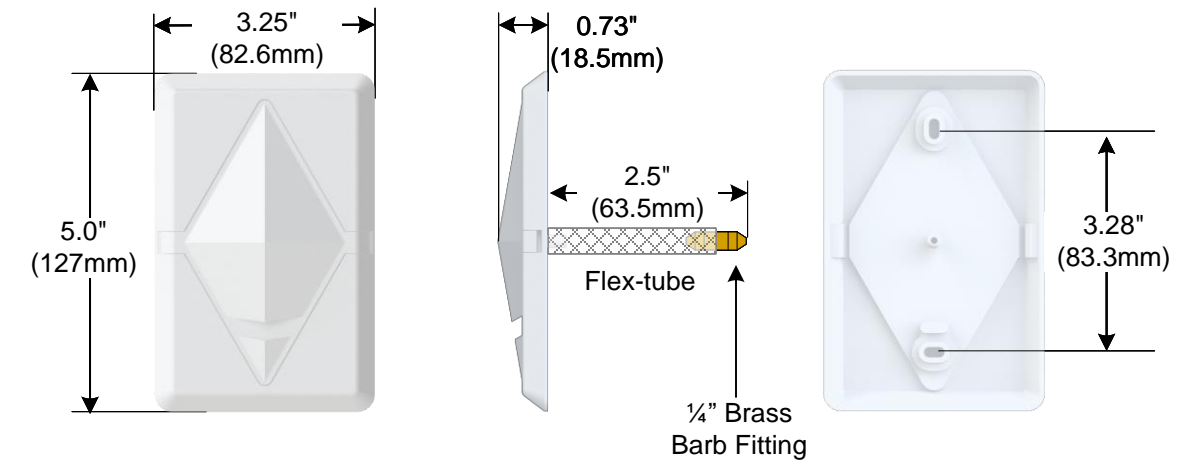

Materials

All Materials are RoHS Compliant
 IO Module Enclosure: 16 Gauge Aluminum Alloy 5052-H32
 Display Module Bezel & Mounting Plate: ABS Plastic UL94-V0
 Sensor Probe and Reference Probe: ABS Plastic UL94-V0
 Display Cable: Plenum-rated shielded cable

DWG. NO:	Iso-Tek SUBMITTAL		
REVISION:	F	ECN:	2935
REV. DATE:	12-11-23	SHEET:	2 OF 4

INSTALLATION

Display Module

The Display Module is designed to be installed onto a standard double or triple-gang electrical box (e-box) provided by others. The e-box is typically located at eye-level at the entrance of the room being monitored.

Step 1: Install the e-box level & flush with finished wall surface.

Step 2: Insert Display Cable from e-box through the hole located in the Display Mounting Plate.

Step 3: Position the Display Mounting Plate with the arrow UP and secure to e-box using the (4) #6-32 x 1" long screws provided.

CAUTION: Do not overtighten mounting screws. Overtightening may deform mounting plate.

Step 4: Align the notches in the top of Display with slots in the top of the Mounting Plate.

Step 5: Tighten the (2) screws located at the bottom of the Display to secure the Bezel to the Backplate.

DO NOT REMOVE SCREWS

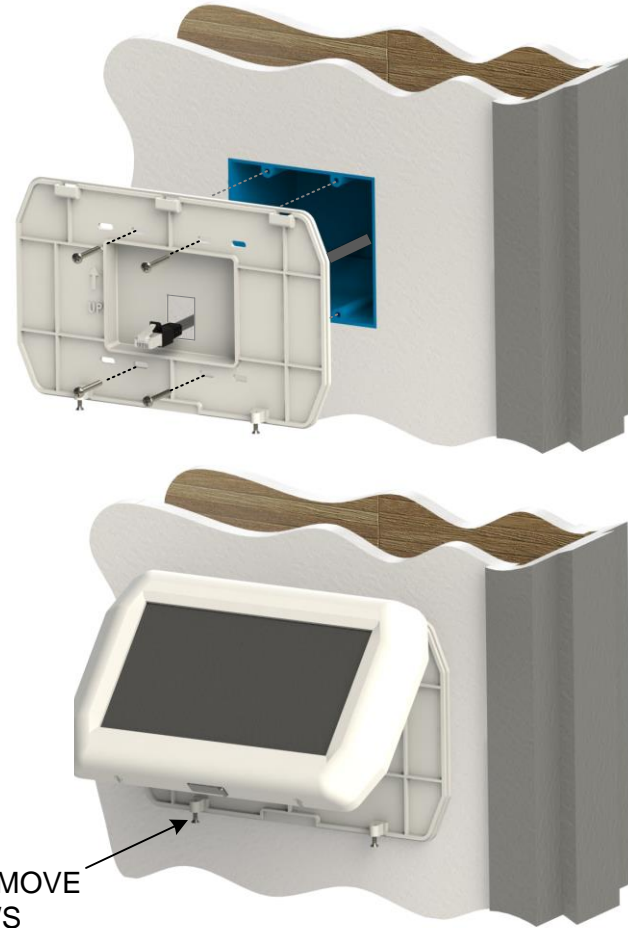

IO Module

The IO Module enclosure includes 4 flanges with 0.2" dia holes provided for securing the IO Module to a wall or panel plate. The IO Module is typically located in the vicinity of the room above the ceiling or inside a control panel that is within the range of the display cable provided.

Secure IO Module to mounting surface using either (4) #8 or #10 screws (Provided by others).

For sheetrock installation, use the appropriate wall anchors (provided by others).



Sensor Probe & Reference Probe

The Sensor and Reference Probes are designed to be installed onto a single-gang electrical box (e-box). The sensor probe shall be located inside of the pressurized space and the reference probe shall be installed outside the pressurized space in a location designated as the reference pressure zone for the room being monitored. Both probes shall be located in areas that will not be influenced by air currents from supply diffusers, fans, personnel, etc..

Step 1: Install the e-box level & flush with finished wall surface.

Step 2: Run field tubing (by others) from Sensor Probe e-box to Reference Probe e-box.

Step 3: Each probe is provided with a short length of kink-proof tubing with a 1/4" barb fitting. Connect the field tubing to the barb fitting on the Sensor Probe and Reference Probe.

Field tubing: 0.25" (6mm) O.D., .040" (1mm) wall, NFPA 90 flame retardant polyethylene control tubing, such as Chevron Plexco or equivalent approved by local building codes.



Factory Supplied kink-proof tubing

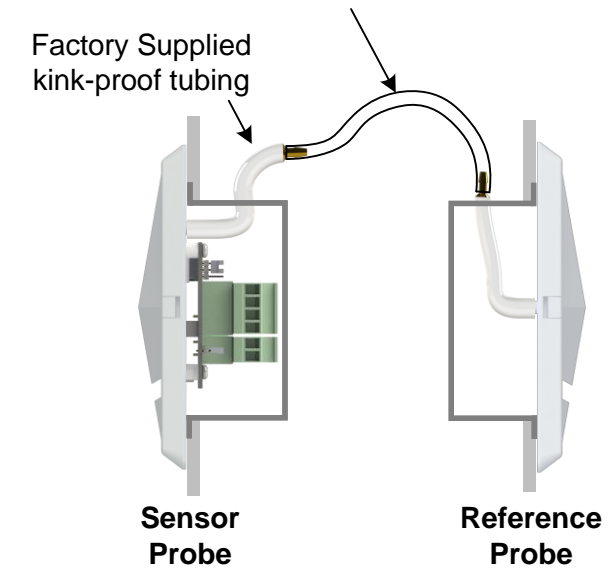

Sensor Probe

Reference Probe

Step 4: Remove airflow deflector plates on both probes to reveal mounting holes by pulling outwards on the side tabs.

Step 5: Position the Probe with the arrow UP and secure to e-box using the (2) #6-32 x 1" long screws with attached gasket provided.

CAUTION: Do not overtighten mounting screws. Overtightening may deform mounting plate.

Step 6: After installation is complete, reattach the airflow deflector plates.



WIRING

CAUTION: Maintain polarity when power source is used to power multiple devices otherwise equipment may be damaged.

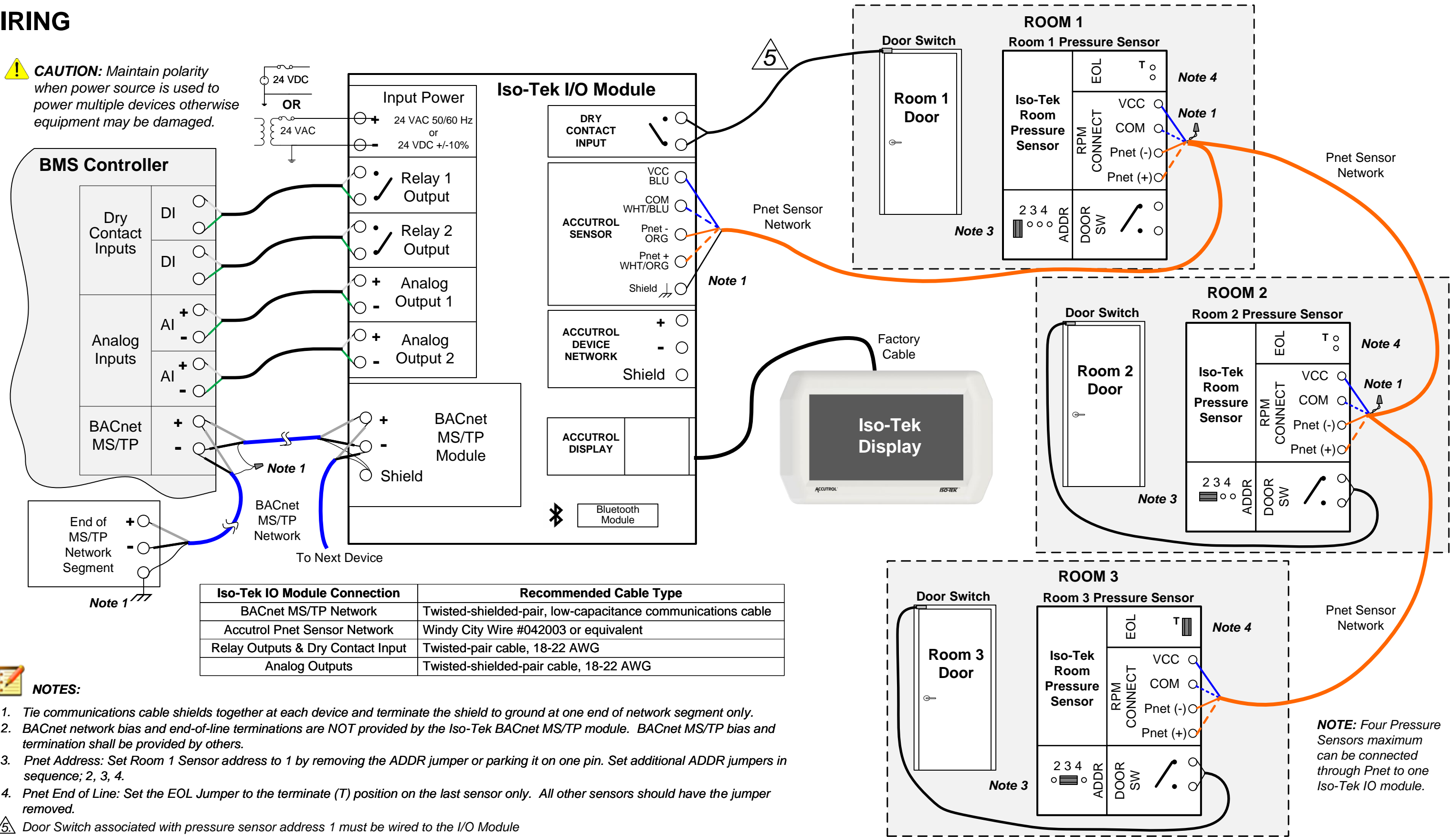

Iso-Tek IO Module Connection	Recommended Cable Type
BACnet MS/TP Network	Twisted-shielded-pair, low-capacitance communications cable
Accutrol Pnet Sensor Network	Windy City Wire #042003 or equivalent
Relay Outputs & Dry Contact Input	Twisted-pair cable, 18-22 AWG
Analog Outputs	Twisted-shielded-pair cable, 18-22 AWG



NOTES:

1. Tie communications cable shields together at each device and terminate the shield to ground at one end of network segment only.
 2. BACnet network bias and end-of-line terminations are NOT provided by the Iso-Tek BACnet MS/TP module. BACnet MS/TP bias and termination shall be provided by others.
 3. Pnet Address: Set Room 1 Sensor address to 1 by removing the ADDR jumper or parking it on one pin. Set additional ADDR jumpers in sequence; 2, 3, 4.
 4. Pnet End of Line: Set the EOL Jumper to the terminate (T) position on the last sensor only. All other sensors should have the jumper removed.
- ⚠ Door Switch associated with pressure sensor address 1 must be wired to the I/O Module

NOTE: Four Pressure Sensors maximum can be connected through Pnet to one Iso-Tek IO module.



Accutrol Representative:

SUBMITTAL DRAWING

Iso-Tek®

THIS DOCUMENT IS SUBJECT TO CHANGE WITHOUT NOTICE. THIS DOCUMENT OR THE CONTENTS THEREOF SHALL NOT BE MODIFIED WITHOUT PRIOR WRITTEN PERMISSION BY ACCUTROL LLC.

DWG. NO:	Iso-Tek SUBMITTAL		
REVISION:	F	ECN:	2935
REV. DATE:	12-11-23	SHEET:	4 OF 4